



Samsung Electronics Co.,Ltd.
Printed in Korea
03/2001 Rev 1.0
GH68-02128A



DUAL BAND Mobile Cellular Phone SGH-R210S

SERVICE Manual

DUAL BAND MOBILE CELLULAR PHONE



CONTENTS

1. Exploded Views and Parts List
2. PCB Diagrams
3. Electrical Parts List
4. Block Diagrams
5. Flow Chart of Troubleshooting and Circuit Diagrams

1. Exploded Views and Parts List

- 1-1 Main
- 1-2 Main Parts List
- 1-3 Travel Adapter
- 1-4 Travel Adapter Parts List
- 1-5 Ciger Light Adapter
- 1-6 Ciger Light Adapter Parts List
- 1-7 Test Jig
- 1-8 EAR Microphone
- 1-9 Data Kit
- 1-10 Battery Charger

2. PCB Diagrams

- 2-1 Main Top
- 2-2 Main Bottom

3. Electrical Parts List

- 3-1 Main Parts List Top
- 3-2 Main Parts List Bottom

4. Block Diagrams

- 4-1 Main Baseband
- 4-2 Main RF
 - 4-2-1 RF Transmit Part
 - 4-2-2 RF Receive Part

5. Flow Chart of Troubleshooting and Circuit Diagrams

- 5-1 Power ON
 - 5-2 Initial
 - 5-3 Charging Part
 - 5-4 Sim Part
 - 5-5 Microphone Part
 - 5-6 Speaker Part
 - 5-7 Key Data Input
 - 5-8 Alert Tone
 - 5-9 Ring Indicator
 - 5-10 Back Light
 - 5-11 GSM Receiver
 - 5-12 GSM Transmitter
 - 5-13 DCS Receiver
 - 5-14 DCS Transmitter
-

1. Exploded Views and Parts List

1-1 Main

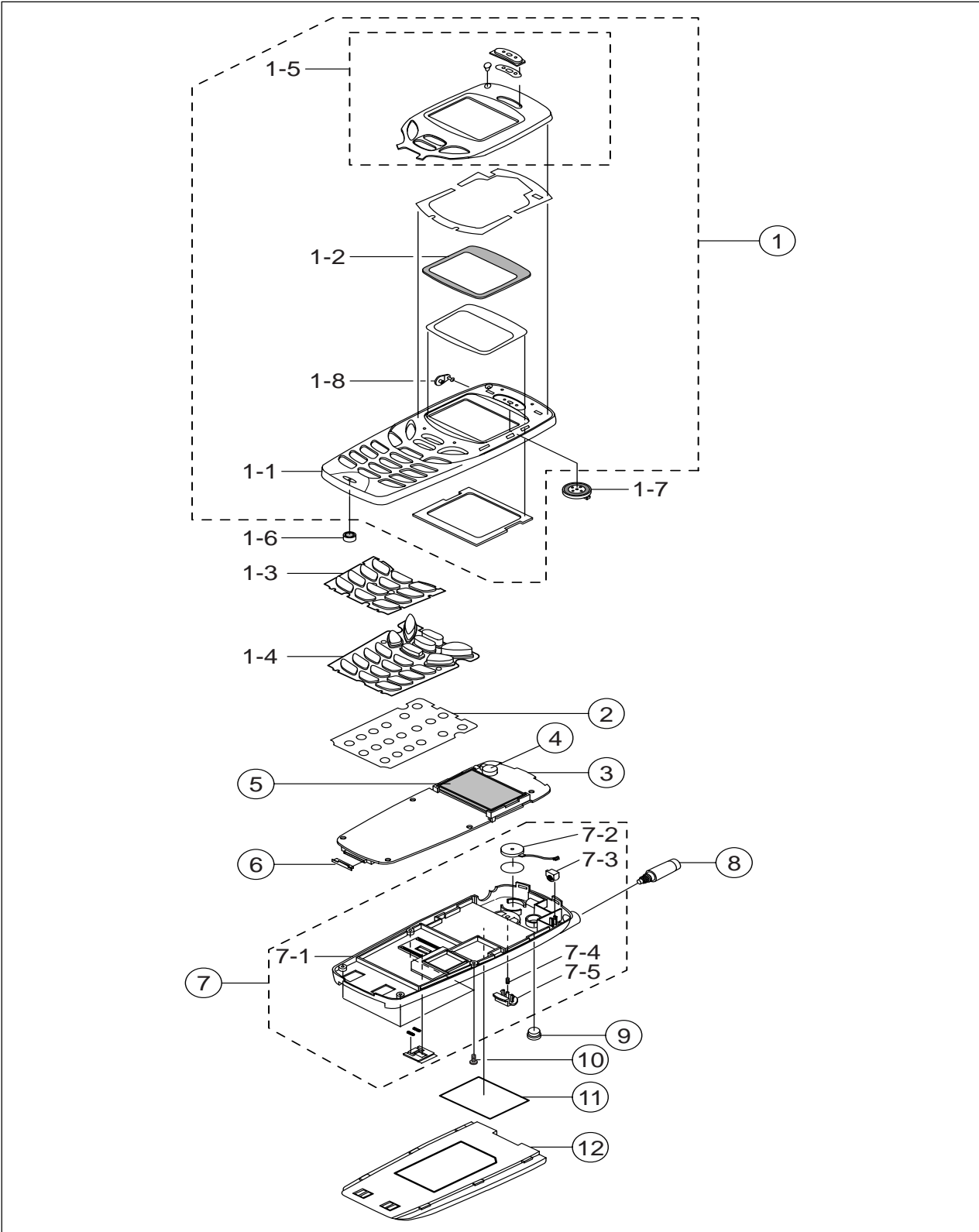

1-2 Main Parts List

Location No.		Description	SEC CODE			Remark
			Navy Blue	Green	Dark Gray	
1		MEC-FRONT COVER	GH75-01159A	GH75-01159B	GH75-01159C	SA
	1-1	FRONT COVER	GH72-02666A	GH72-02666B	GH72-02666C	SNA
	1-2	WINDOW LCD	GH72-02672A	GH72-02672A	GH72-02672A	SNA
	1-3	FI KEY	GH72-02784A	GH72-02784A	GH72-02784A	SA
	1-4	MEC-KEYPAD	GH75-01160A	GH75-01160A	GH75-01160A	SA
	1-5	MEC-DUMMY COVER	GH75-01161A	GH75-01161A	GH75-01161A	SNA
	1-6	MIC	GH59-00240B	GH59-00240B	GH59-00240B	SA
	1-7	SPEAKER	3001-001233	3001-001233	3001-001233	SA
	1-8	EARPHONE COVER	GH73-00757A	GH73-00757B	GH73-00757C	SNA
2		DOME SHEET	GH72-02984B	GH72-02984B	GH72-02984B	SA
3		MAIN PBA	GH92-01200A	GH92-01200A	GH92-01200A	SA
4		BUZZER	3002-001098	3002-001098	3002-001098	SA
5		DISPLAY LCD	GH07-00075B	GH07-00075B	GH07-00075B	SA
6		I/F COVER	GH73-00758A	GH73-00758B	GH73-00758C	SA
7		MEC-REAR COVER	GH75-01165A	GH75-01165B	GH75-01165C	SA
	7-1	REAR COVER	GH72-02674A	GH72-02674B	GH72-02674C	SNA
	7-2	VIBRATOR	GH31-00019A	GH31-00019A	GH31-00019A	SA
	7-3	BRACKET-ANT	GH71-00505A	GH71-00505A	GH71-00505A	SNA
	7-4	SPRING LOCKER	GH70-10633A	GH70-10633A	GH70-10633A	SNA
	7-5	LOCKER MAIN	GH72-02676A	GH72-02676B	GH72-02676C	SNA
8		ANTENNA	GH42-00120C	GH42-00120B	GH42-00120A	SA
9		R/F COVER	GH73-00759A	GH73-00759B	GH73-00759C	SA
10		SCREW-MACHINE	6001-001542	6001-001542	6001-001542	SA
11		LABEL	GH68-02109A	GH68-02109A	GH68-02109A	SA
12		BATTERY	GH43-00369A	GH43-00369B	GH43-00369C	SA

1-3 Travel Adapter

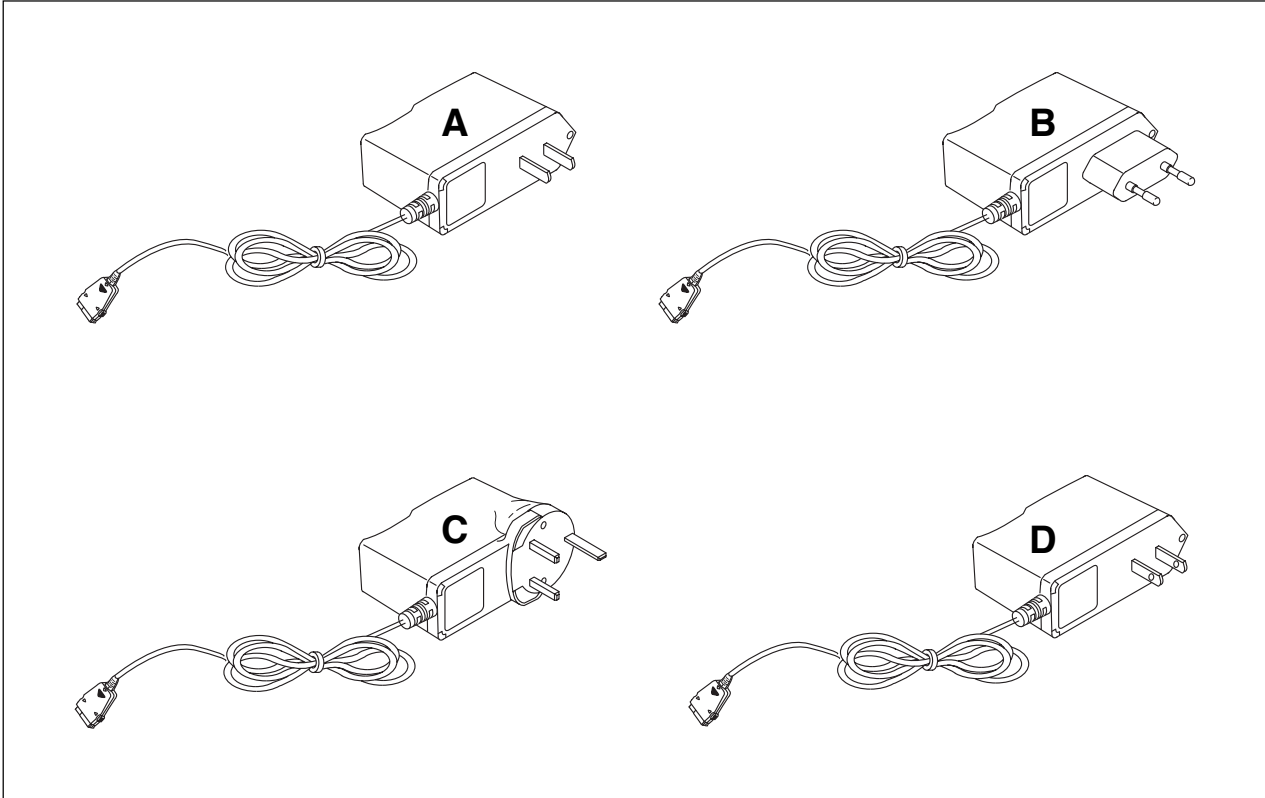

1-4 Travel Adapter Parts List

TYPE	SEC CODE	REMARK
A	GH44-00171A	CHINA
B	GH44-00184A	EUROPE
C	GH44-00171C	UNITED KINGDOM
D	Gh44-00171E	TAIWAN

1-5 Ciger Light Adapter

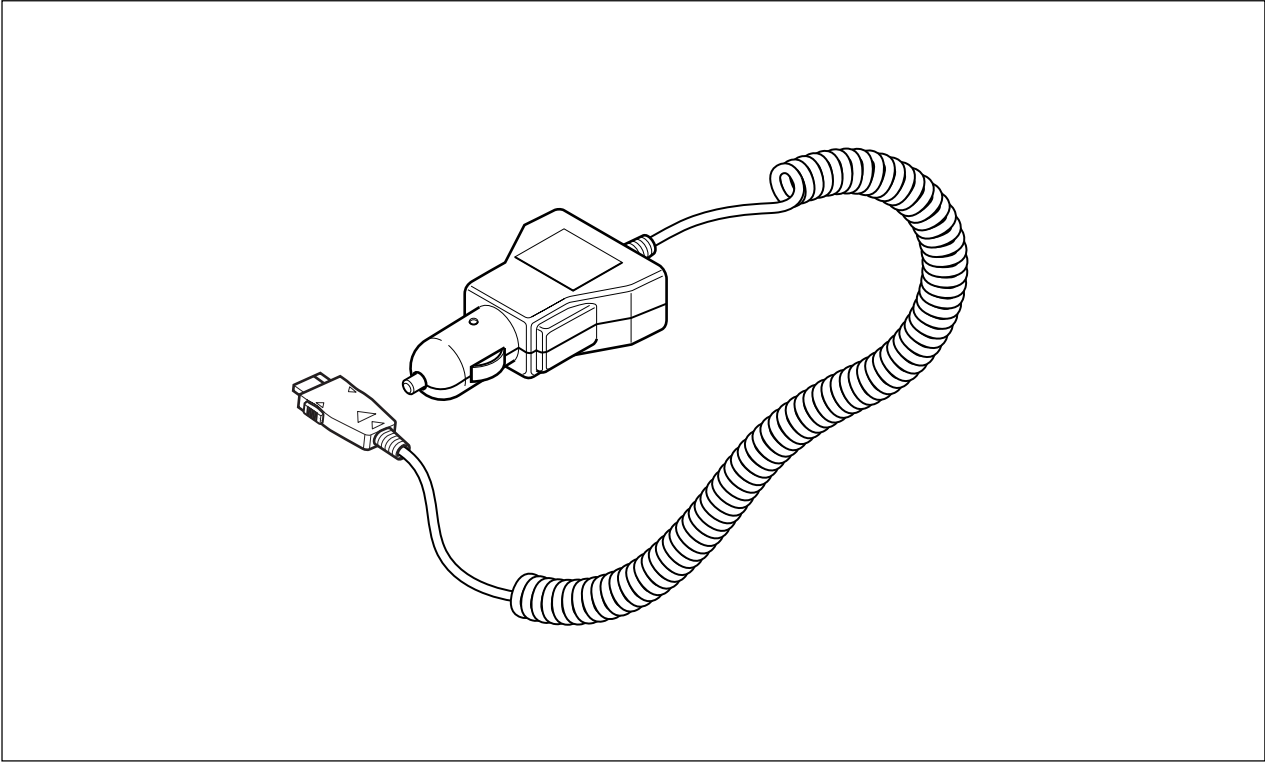

1-6 Ciger Light Adapter Parts List

DESCRIPTION	SEC CODE	REMARK
Ciger Light Adapter Code	GH44-00170A	BLACK

1-7 Test Jig

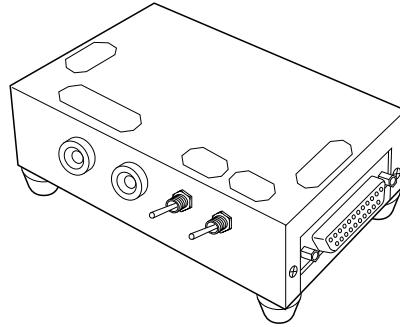

TEST JIG

GH80-10508A

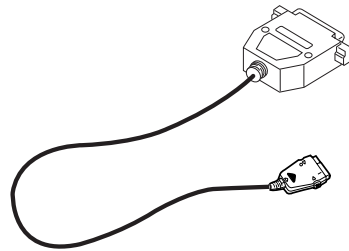

TEST JIG CABLE

GH39-00079A

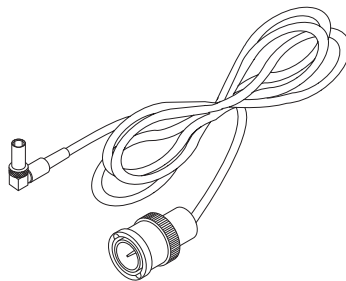

RF CABLE

GH39-00090A

1-7-1 Test Jig

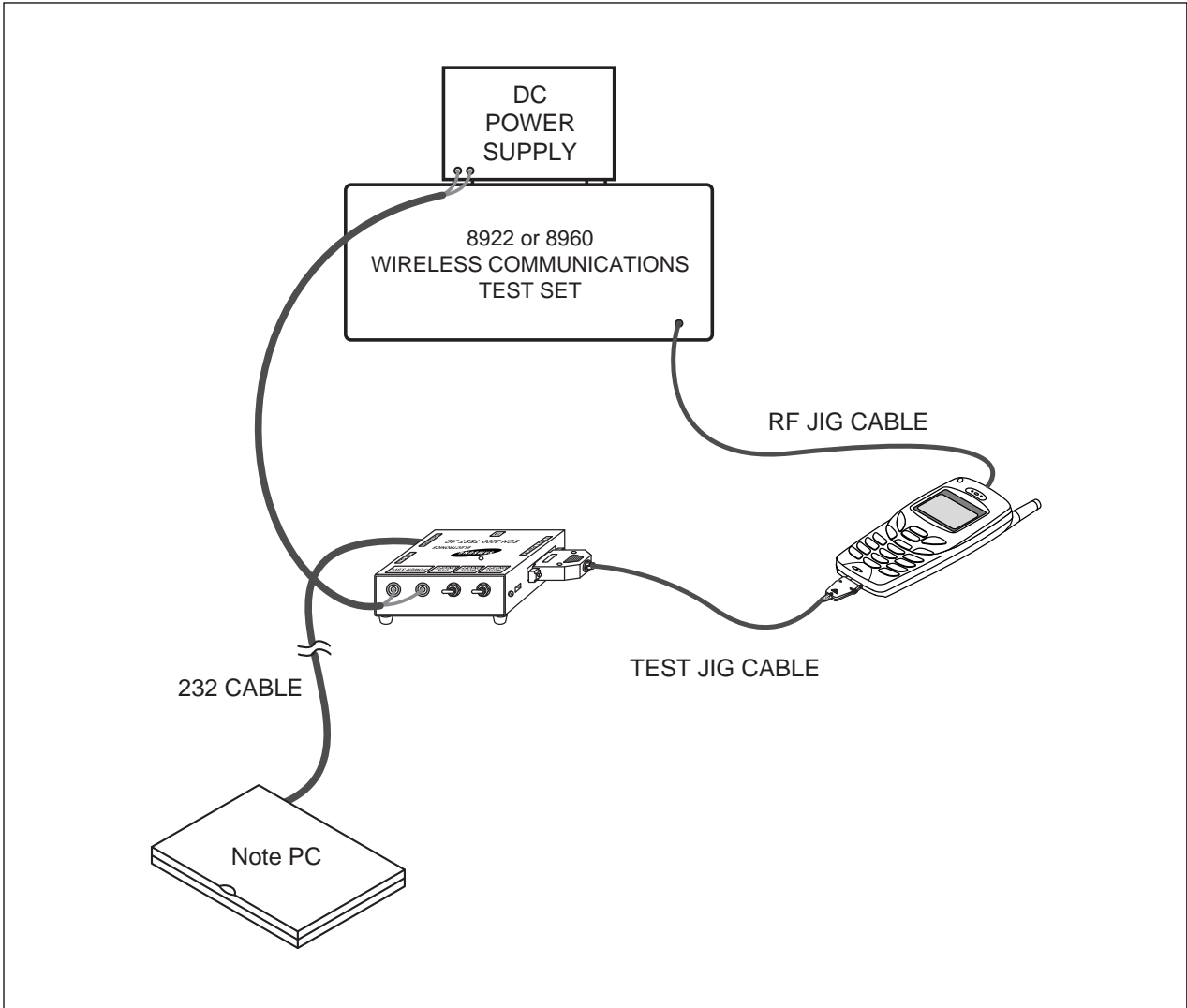

1-8 EAR Microphone

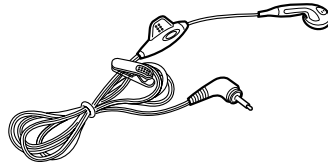

EAR MICROPHONE

GH59-00225B

1-9 Data Kit

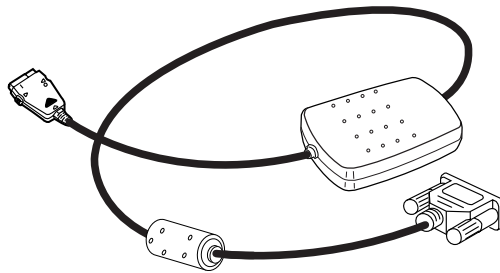

DATA KIT

GH39-00078A

1-10 Battery Charger

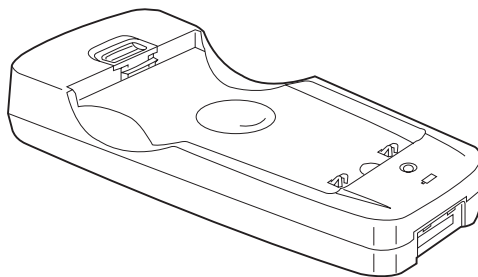

BATTERY CHARGER

GH44-00234A

2. PCB Diagrams

2-1 Main Top

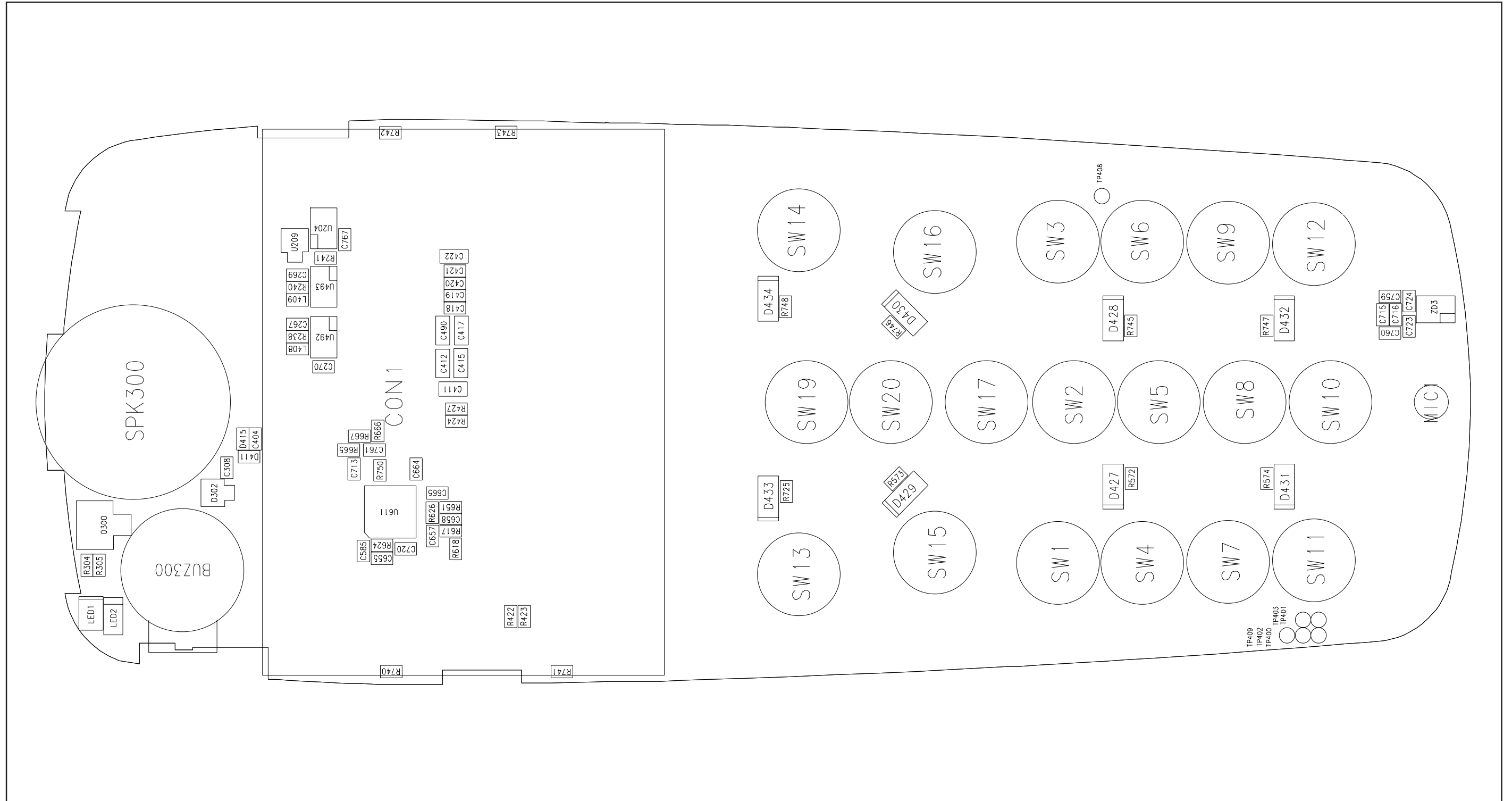

2-2 Main Bottom

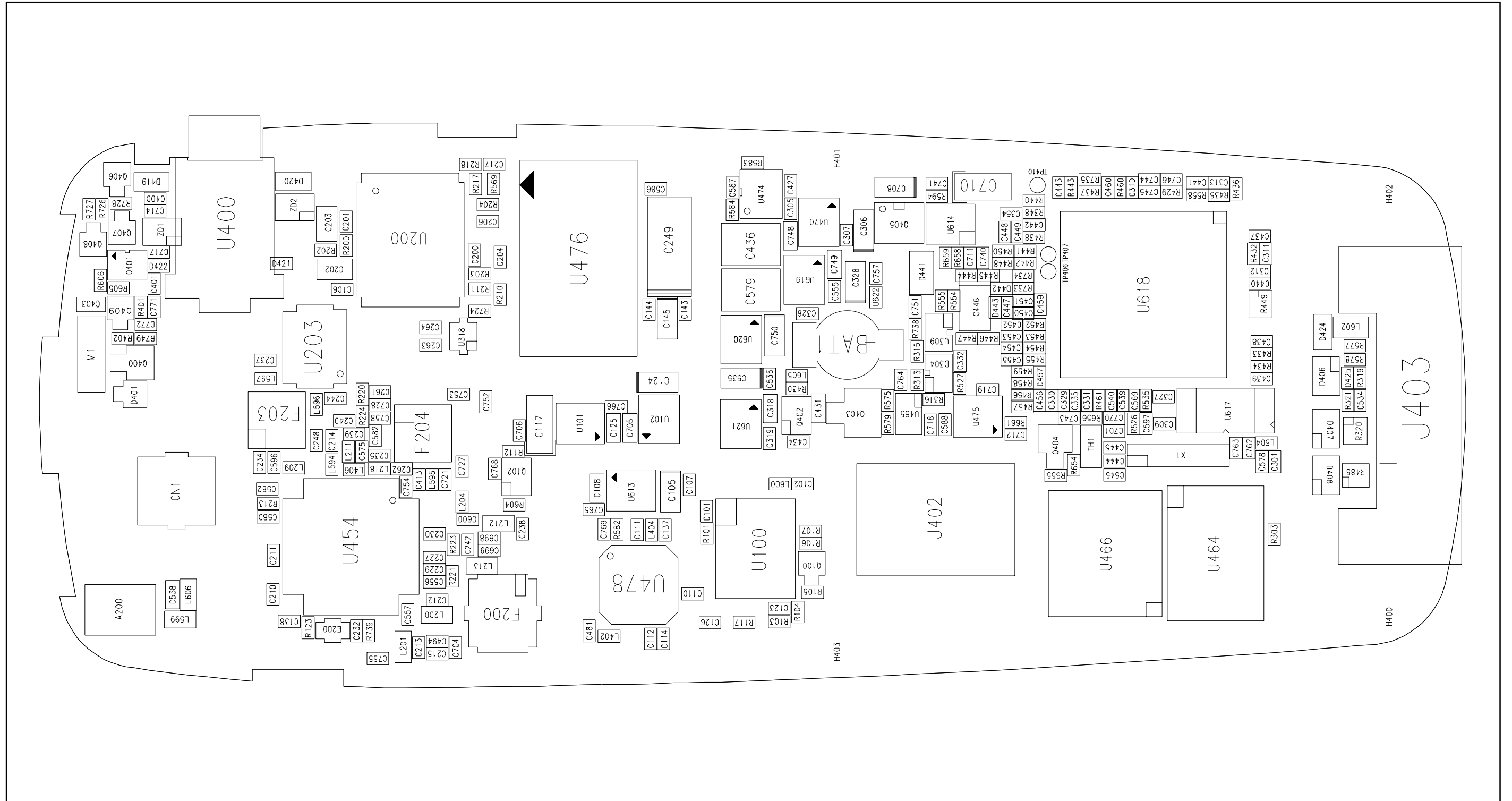

3. Electrical Parts List

3-1 Main Parts List Top

NO	SEC CODE	Reference	Part Description	Vendor Part No.
1	0401-001033	D441	"DIODE-SWITCHING,MCL4154,25V,200mA,M-MELF"	MCL4154
2	0406-001083	D406	"DIODE-TVS,6.1/-7.2V,150W,SOT-323-5L"	ESDA6V1W5
3	0406-001083	D407	"DIODE-TVS,6.1/-7.2V,150W,SOT-323-5L"	ESDA6V1W5
4	0406-001083	D408	"DIODE-TVS,6.1/-7.2V,150W,SOT-323-5L"	ESDA6V1W5
5	0407-001002	D401	"DIODE-ARRAY,DAN222,80V,300mA,CA2-3,EM3"	DAN222
6	0407-001007	D304	"DIODE-ARRAY,UMN1,80V,25mA,CA4-2,UM5"	UMN1
7	0501-000162	Q404	"TR-SMALL SIGNAL,2SA1576,PNP,200MW,SOT-323"	2SA1576
8	0501-000162	Q400	"TR-SMALL SIGNAL,2SA1576,PNP,200MW,SOT-323"	2SA1576
9	0501-000225	Q100	"TR-SMALL SIGNAL,2SC4617,NPN,200mW,EM3"	2SC4617
10	0501-002011	Q403	"TR-SMALL SIGNAL,2SD2114K,NPN,200mW,SOT-23"	2SD2114KT146V
11	0502-001201	Q405	"TR-POWER,ZXT13P20DE6,PNP,1100MW,SOT-23-6"	ZXT13P20DE6
12	0504-000167	U615	"TR-DIGITAL,RN1102,NPN,100MW,10K/10K"	DTC114EE/TR
13	0504-000167	Q409	"TR-DIGITAL,RN1102,NPN,100MW,10K/10K"	DTC144EE/TR
14	0504-001012	Q406	"TR-DIGITAL,DTC114YE,NPN,150MW,10K/47K"	DTC114YE
15	0504-001012	Q407	"TR-DIGITAL,DTC114YE,NPN,150MW,10K/47K"	DTC114YE
16	0504-001012	Q408	"TR-DIGITAL,DTC114YE,NPN,150MW,10K/47K"	DTC114YE
17	0504-001021	U616	"TR-DIGITAL,DTB113ZK,PNP,200MW,10K,SC-59"	DTB113ZK
18	0504-001058	U465	"TR-DIGITAL,RN4985,NPN/PNP,200mW,2.2Kohm"	RN4985
19	0505-001332	Q401	"FET-SILICON,FDG6301,N,25V,0.22A,SC70-6"	FDG6301N
20	0505-001376	U474	"FET-SILICON,FDC6329L,N/P,8V,2.5A,0.7W,SC-74"	SI3865DV
21	0505-001570	Q102	"FET-SILICON,SI1865DL"	SI1865DL
22	0505-001570	Q402	"FET-SILICON,SI1865DL"	SI1865DL
23	0506-001004	U309	"TR-ARRAY,UMC5N,NPN/PNP,2,50V,-,100mA,3"	UMC5NTR
24	0601-001542	LED3	"LED,CHIP,BLUE,1.2X0.8MM,480NM"	E1S03-AB1A7
25	0601-001542	LED4	"LED,CHIP,BLUE,1.2X0.8MM,480NM"	E1S03-AB1A7
26	0601-001542	LED5	"LED,CHIP,BLUE,1.2X0.8MM,480NM"	E1S03-AB1A7
27	0601-001542	LED6	"LED,CHIP,BLUE,1.2X0.8MM,480NM"	E1S03-AB1A7
28	1103-001185	U617	"IC-EEPROM,24A2561,32Kx8Bit,TSSOP,8P"	S524AD0XF1
29	1106-001326	U464	"IC-SRAM,616FU4110,256Kx16Bit,uBGA,48P"	KM616FU4110CFI-7
30	1107-001304	U466	"IC-FLASH MEMORY,AM29DL162,2MX8BIT,48P"	AM29DL162DT-90WCI
31	1201-001785	U476	"IC-POWER AMP,08122,-,8P,-,DUAL,34DB"	PF08122B-TB
32	1203-001204	U470	"IC-VOLTAGE REGULATOR,2981,SOT-23,5P,59MIL"	LP2981AIM5X-3.3
33	1203-001454	U101	"IC-VOLTAGE REGULATOR,2981,SOT-23,5P,59MIL"	LP2981AIM5X-3.0
34	1203-001454	U102	"IC-VOLTAGE REGULATOR,2981,SOT-23,5P,59MIL"	LP2981AIM5X-3.0
35	1203-001701	U613	"IC-VOLTAGE REGULATOR,2982,SOT-23,5P,3.0V"	LP2982AIM5X-3.0
36	1203-002127	U614	"IC-BATTERY,1734,SOT-23,6P,150MIL"	LTC1734ES6-4.2#TR
37	1203-002128	U619	"IC-VOLTAGE REGULATOR,2985,MICRO SMD,5P"	LP2985AIBPX-3.0
38	1203-002128	U620	"IC-VOLTAGE REGULATOR,2985,MICRO SMD,5P"	LP2985AIBPX-3.0

NO	SEC CODE	Reference	Part Description	Vendor Part No.
39	1203-002160	U621	"IC-VOLTAGE REGULATOR,2981,SMD,5P,63MIL"	LP2981AIBPX-3.3
40	1203-002247	U475	"IC-VOL. DETECTOR,S-809,SOT-23-5,5P"	S-80926ALMP-DAP-T2
41	1205-001881	U618	"IC-COMM. CONTROLLER,VP40575,BGA,180P"	VP40575
42	1205-001935	U454	"IC-TRANSCIEVER,HD155128TF,TP,56P,-,-,3V"	HD155128TF
43	1209-001337	U478	"IC-PLL/SYNTHESISER,LCC,28P,3.6V,-40to+85C"	SI4133-MLP28
44	1404-001005	TH1	"THERMISTOR-NTC,47Kohm,5%,4050K,2.0mW/C"	NTH5G20P40B473J07TE
45	1405-001018	D419	"VARISTOR,14V,-,1.6x0.8mm,TP"	VC060314A300R
46	1405-001018	D420	"VARISTOR,14V,-,1.6x0.8mm,TP"	VC060314A300R
47	1405-001018	D424	"VARISTOR,14V,-,1.6x0.8mm,TP"	VC060314A300R
48	1405-001082	D435	"VARISTOR,5.6V,20A,1x0.5x0.6mm"	VC04025X150R
49	1405-001082	D436	"VARISTOR,5.6V,20A,1x0.5x0.6mm"	VC04025X150R
50	1405-001082	D437	"VARISTOR,5.6V,20A,1x0.5x0.6mm"	VC04025X150R
51	1405-001082	D438	"VARISTOR,5.6V,20A,1x0.5x0.6mm"	VC04025X150R
52	1405-001082	D439	"VARISTOR,5.6V,20A,1x0.5x0.6mm"	VC04025X150R
53	1405-001082	D440	"VARISTOR,5.6V,20A,1x0.5x0.6mm"	VC04025X150R
54	1405-001093	D421	"VARISTOR,14V,20A,1x0.5x0.6mm"	VC040214X500R
55	1405-001093	D422	"VARISTOR,14V,20A,1x0.5x0.6mm"	VC040214X500R
56	1405-001093	D425	"VARISTOR,14V,20A,1x0.5x0.6mm"	VC040214X500R
57	1405-001093	D442	"VARISTOR,14V,20A,1x0.5x0.6mm"	VC040214X500R
58	1405-001093	D443	"VARISTOR,14V,20A,1x0.5x0.6mm"	VC040214X500R
59	2007-000138	R200	"R-CHIP,100ohm,5%,1/16W,DA,TP,1005"	RK73K1ETP101J
60	2007-000138	R321	"R-CHIP,100ohm,5%,1/16W,DA,TP,1005"	RK73K1ETP101J
61	2007-000139	R203	"R-CHIP,220ohm,5%,1/16W,DA,TP,1005"	RK73K1ETP221J
62	2007-000139	R204	"R-CHIP,220ohm,5%,1/16W,DA,TP,1005"	RK73K1ETP221J
63	2007-000139	R444	"R-CHIP,220ohm,5%,1/16W,DA,TP,1005"	RK73K1ETP221J
64	2007-000139	R447	"R-CHIP,220ohm,5%,1/16W,DA,TP,1005"	RK73K1ETP221J
65	2007-000140	R106	"R-CHIP,1Kohm,5%,1/16W,DA,TP,1005"	RK73K1ETP102J
66	2007-000140	R107	"R-CHIP,1Kohm,5%,1/16W,DA,TP,1005"	RK73K1ETP102J
67	2007-000140	R575	"R-CHIP,1Kohm,5%,1/16W,DA,TP,1005"	RK73K1ETP102J
68	2007-000140	R584	"R-CHIP,1Kohm,5%,1/16W,DA,TP,1005"	RK73K1ETP102J
69	2007-000140	R738	"R-CHIP,1Kohm,5%,1/16W,DA,TP,1005"	RK73K1ETP102J
70	2007-000141	R103	"R-CHIP,2.2Kohm,5%,1/16W,DA,TP,1005"	RK73K1ETP222J
71	2007-000141	R223	"R-CHIP,2.2Kohm,5%,1/16W,DA,TP,1005"	RK73K1ETP222J
72	2007-000141	R433	"R-CHIP,2.2Kohm,5%,1/16W,DA,TP,1005"	RK73K1ETP222J
73	2007-000141	R434	"R-CHIP,2.2Kohm,5%,1/16W,DA,TP,1005"	RK73K1ETP222J
74	2007-000145	R117	"R-CHIP,6.2Kohm,5%,1/16W,DA,TP,1005"	RK73K1ETP622J
75	2007-000148	R101	"R-CHIP,10Kohm,5%,1/16W,DA,TP,1005"	RK73K1ETP103J
76	2007-000148	R112	"R-CHIP,10Kohm,5%,1/16W,DA,TP,1005"	RK73K1ETP103J
77	2007-000148	R303	"R-CHIP,10Kohm,5%,1/16W,DA,TP,1005"	RK73K1ETP103J
78	2007-000148	R313	"R-CHIP,10Kohm,5%,1/16W,DA,TP,1005"	RK73K1ETP103J
79	2007-000148	R315	"R-CHIP,10Kohm,5%,1/16W,DA,TP,1005"	RK73K1ETP103J
80	2007-000148	R348	"R-CHIP,10Kohm,5%,1/16W,DA,TP,1005"	RK73K1ETP103J

NO	SEC CODE	Reference	Part Description	Vendor Part No.
81	2007-000148	R430	"R-CHIP,10Kohm,5%,1/16W,DA,TP,1005"	RK73K1ETP103J
82	2007-000148	R435	"R-CHIP,10Kohm,5%,1/16W,DA,TP,1005"	RK73K1ETP103J
83	2007-000148	R438	"R-CHIP,10Kohm,5%,1/16W,DA,TP,1005"	RK73K1ETP103J
84	2007-000148	R450	"R-CHIP,10Kohm,5%,1/16W,DA,TP,1005"	RK73K1ETP103J
85	2007-000148	R461	"R-CHIP,10Kohm,5%,1/16W,DA,TP,1005"	RK73K1ETP103J
86	2007-000148	R526	"R-CHIP,10Kohm,5%,1/16W,DA,TP,1005"	RK73K1ETP103J
87	2007-000148	R527	"R-CHIP,10Kohm,5%,1/16W,DA,TP,1005"	RK73K1ETP103J
88	2007-000148	R535	"R-CHIP,10Kohm,5%,1/16W,DA,TP,1005"	RK73K1ETP103J
89	2007-000148	R554	"R-CHIP,10Kohm,5%,1/16W,DA,TP,1005"	RK73K1ETP103J
90	2007-000148	R558	"R-CHIP,10Kohm,5%,1/16W,DA,TP,1005"	RK73K1ETP103J
91	2007-000148	R604	"R-CHIP,10Kohm,5%,1/16W,DA,TP,1005"	RK73K1ETP103J
92	2007-000148	R654	"R-CHIP,10Kohm,5%,1/16W,DA,TP,1005"	RK73K1ETP103J
93	2007-000148	R655	"R-CHIP,10Kohm,5%,1/16W,DA,TP,1005"	RK73K1ETP103J
94	2007-000148	R661	"R-CHIP,10Kohm,5%,1/16W,DA,TP,1005"	RK73K1ETP103J
95	2007-000148	R723	"R-CHIP,10Kohm,5%,1/16W,DA,TP,1005"	RK73K1ETP103J
96	2007-000152	R429	"R-CHIP,20Kohm,5%,1/16W,DA,TP,1005"	RK73K1ETP203J
97	2007-000153	R213	"R-CHIP,22Kohm,5%,1/16W,DA,TP,1005"	RK73K1ETP223J
98	2007-000155	R104	"R-CHIP,27Kohm,5%,1/16W,DA,TP,1005"	RK73K1ETP273J
99	2007-000157	R441	"R-CHIP,47Kohm,5%,1/16W,DA,TP,1005"	RK73K1ETP473J
100	2007-000157	R442	"R-CHIP,47Kohm,5%,1/16W,DA,TP,1005"	RK73K1ETP473J
101	2007-000157	R443	"R-CHIP,47Kohm,5%,1/16W,DA,TP,1005"	RK73K1ETP473J
102	2007-000159	R656	"R-CHIP,56Kohm,5%,1/16W,DA,TP,1005"	RK73K1ETP563J
103	2007-000162	R316	"R-CHIP,100Kohm,5%,1/16W,DA,TP,1005"	RK73K1ETP104J
104	2007-000142	R402	"R-CHIP,1Kohm,5%,1/16W,DA,TP,1005"	RK73K1ETP102J
105	2007-000162	R432	"R-CHIP,100Kohm,5%,1/16W,DA,TP,1005"	RK73K1ETP104J
106	2007-000162	R437	"R-CHIP,100Kohm,5%,1/16W,DA,TP,1005"	RK73K1ETP104J
107	2007-000162	R460	"R-CHIP,100Kohm,5%,1/16W,DA,TP,1005"	RK73K1ETP104J
108	2007-000162	R555	"R-CHIP,100Kohm,5%,1/16W,DA,TP,1005"	RK73K1ETP104J
109	2007-000162	R579	"R-CHIP,100Kohm,5%,1/16W,DA,TP,1005"	RK73K1ETP104J
110	2007-000162	R583	"R-CHIP,100Kohm,5%,1/16W,DA,TP,1005"	RK73K1ETP104J
111	2007-000162	R605	"R-CHIP,100Kohm,5%,1/16W,DA,TP,1005"	RK73K1ETP104J
112	2007-000162	R606	"R-CHIP,100Kohm,5%,1/16W,DA,TP,1005"	RK73K1ETP104J
113	2007-000168	R440	"R-CHIP,470Kohm,5%,1/16W,DA,TP,1005"	RK73K1ETP474J
114	2007-000168	R735	"R-CHIP,470Kohm,5%,1/16W,DA,TP,1005"	RK73K1ETP474J
115	2007-000172	R220	"R-CHIP,10ohm,5%,1/16W,DA,TP,1005"	RK73K1ETP100J
116	2007-000172	R224	"R-CHIP,10ohm,5%,1/16W,DA,TP,1005"	RK73K1ETP100J
117	2007-000172	R577	"R-CHIP,10ohm,5%,1/16W,DA,TP,1005"	RK73K1ETP100J
118	2007-000172	R578	"R-CHIP,10ohm,5%,1/16W,DA,TP,1005"	RK73K1ETP100J
119	2007-000172	R664	"R-CHIP,10ohm,5%,1/16W,DA,TP,1005"	RK73K1ETP100J
120	2007-000172	R731	"R-CHIP,10ohm,5%,1/16W,DA,TP,1005"	RK73K1ETP100J
121	2007-000172	R736	"R-CHIP,10ohm,5%,1/16W,DA,TP,1005"	RK73K1ETP100J
122	2007-000172	R737	"R-CHIP,10ohm,5%,1/16W,DA,TP,1005"	RK73K1ETP100J

NO	SEC CODE	Reference	Part Description	Vendor Part No.
123	2007-000174	R123	"R-CHIP,47ohm,5%,1/16W,DA,TP,1005"	RK73K1ETP470J
124	2007-000174	R569	"R-CHIP,47ohm,5%,1/16W,DA,TP,1005"	RK73K1ETP470J
125	2007-000242	R582	"R-CHIP,1.5Kohm,5%,1/16W,DA,TP,1005"	RK73K1ETP152J
126	2007-007095	R726	"R-CHIP,390ohm,5%,1/16W,DA,TP,1005"	RK73K1ETP681J
127	2007-001244	R105	"R-CHIP,91Kohm,5%,1/16W,DA,TP,1005"	RK73K1ETP913J
128	2007-001298	R221	"R-CHIP,51ohm,5%,1/16W,DA,TP,1005"	RK73K1ETP510J
129	2007-001298	R724	"R-CHIP,51ohm,5%,1/16W,DA,TP,1005"	RK73K1ETP510J
130	2007-001301	R202	"R-CHIP,68ohm,5%,1/16W,DA,TP,1005"	ERJ2GEJ680X
131	2007-001301	R210	"R-CHIP,68ohm,5%,1/16W,DA,TP,1005"	ERJ2GEJ680X
132	2007-001305	R211	"R-CHIP,120ohm,5%,1/16W,DA,TP,1005"	RC1005J121CS
133	2007-002970	R728	"R-CHIP,56ohm,5%,1/16W,DA,TP,1005"	RK73K1ETP560J
134	2007-007009	R727	"R-CHIP,75ohm,5%,1/16W,DA,TP,1005"	RK73K1ETP181J
135	2007-001311	R218	"R-CHIP,270ohm,5%,1/16W,DA,TP,1005"	RK73K1ETP271J
136	2007-002796	R445	"R-CHIP,510ohm,5%,1/16W,DA,TP,1005"	RK73K1ETP511J
137	2007-002796	R446	"R-CHIP,510ohm,5%,1/16W,DA,TP,1005"	RK73K1ETP511J
138	2007-002965	R217	"R-CHIP,15OHM,5%,1/16W,DA,TP,1005"	RK73K1ETP150J
139	2007-007015	R749	"R-CHIP,13KohM,5%1/16W,DA,TP,1005"	RK73K1ETP133J
140	2007-007107	R658	"R-CHIP,100Kohm,1%,1/16W,DA,TP,1005"	RK73H1ETP1003F
141	2007-007317	R452	"R-CHIP,2.2Kohm,1%,1/16W,DA,TP,1005"	RK73H1ETP2201F
142	2007-007317	R453	"R-CHIP,2.2Kohm,1%,1/16W,DA,TP,1005"	RK73H1ETP2201F
143	2007-007317	R454	"R-CHIP,2.2Kohm,1%,1/16W,DA,TP,1005"	RK73H1ETP2201F
144	2007-007317	R455	"R-CHIP,2.2Kohm,1%,1/16W,DA,TP,1005"	RK73H1ETP2201F
145	2007-007317	R594	"R-CHIP,2.2Kohm,1%,1/16W,DA,TP,1005"	RK73H1ETP2201F
146	2007-007318	R456	"R-CHIP,1Kohm,1%,1/16W,DA,TP,1005"	RK73H1ETP1001F
147	2007-007318	R457	"R-CHIP,1Kohm,1%,1/16W,DA,TP,1005"	RK73H1ETP1001F
148	2007-007318	R458	"R-CHIP,1Kohm,1%,1/16W,DA,TP,1005"	RK73H1ETP1001F
149	2007-007318	R459	"R-CHIP,1Kohm,1%,1/16W,DA,TP,1005"	RK73H1ETP1001F
150	2007-007590	R659	"R-CHIP,82Kohm,1%,1/16W,DA,TP,1005"	RK73H1ETP8202F
151	2007-007771	R319	"R-CHIP,0OHM,5%,1/16W,DA,TP,1005"	ERJ2GE0R00L
152	2007-007771	R401	"R-CHIP,0OHM,5%,1/16W,DA,TP,1005"	ERJ2GE0R00L
153	2007-007771	R670	"R-CHIP,0OHM,5%,1/16W,DA,TP,1005"	ERJ2GE0R00L
154	2007-007771	R671	"R-CHIP,0OHM,5%,1/16W,DA,TP,1005"	ERJ2GE0R00L
155	2007-007771	R733	"R-CHIP,0OHM,5%,1/16W,DA,TP,1005"	ERJ2GE0R00L
156	2007-007771	R734	"R-CHIP,0OHM,5%,1/16W,DA,TP,1005"	ERJ2GE0R00L
157	2007-007771	R739	"R-CHIP,0OHM,5%,1/16W,DA,TP,1005"	ERJ2GE0R00L
158	2011-001344	R320	"R-NETWORK,100ohm,5%,1/16W,L,CHIP,8P,TP"	EXB28V101JX
159	2011-001344	R485	"R-NETWORK,100ohm,5%,1/16W,L,CHIP,8P,TP"	EXB28V101JX
160	2011-001345	R449	"R-NETWORK,10Kohm,5%,1/16W,L,CHIP,8P,TP"	EXB28V103JX
161	2203-000233	C144	"C-CERAMIC,CHIP,0.1nF,5%,50V,NP0,TP,1005"	CL05C101JBNC
162	2203-000233	C305	"C-CERAMIC,CHIP,0.1nF,5%,50V,NP0,TP,1005"	CL05C101JBNC
163	2203-000233	C452	"C-CERAMIC,CHIP,0.1nF,5%,50V,NP0,TP,1005"	CL05C101JBNC
164	2203-000233	C453	"C-CERAMIC,CHIP,0.1nF,5%,50V,NP0,TP,1005"	CL05C101JBNC

NO	SEC CODE	Reference	Part Description	Vendor Part No.
165	2203-000233	C454	"C-CERAMIC,CHIP,0.1nF,5%,50V,NP0,TP,1005"	CL05C101JBNC
166	2203-000233	C455	"C-CERAMIC,CHIP,0.1nF,5%,50V,NP0,TP,1005"	CL05C101JBNC
167	2203-000233	C658	"C-CERAMIC,CHIP,0.1nF,5%,50V,NP0,TP,1005"	CL05C101JBNC
168	2203-000233	C718	"C-CERAMIC,CHIP,0.1nF,5%,50V,NP0,TP,1005"	CL05C101JBNC
169	2203-000233	C719	"C-CERAMIC,CHIP,0.1nF,5%,50V,NP0,TP,1005"	CL05C101JBNC
	2203-000233	C764	"C-CERAMIC,CHIP,0.1nF,5%,50V,NP0,TP,1005"	CL05C101JBNC
170	2203-000254	C101	"C-CERAMIC,CHIP,10nF,10%,16V,X7R,TP,1005"	CL05B103KONC
171	2203-000254	C102	"C-CERAMIC,CHIP,10nF,10%,16V,X7R,TP,1005"	CL05B103KONC
172	2203-000254	C123	"C-CERAMIC,CHIP,10nF,10%,16V,X7R,TP,1005"	CL05B103KONC
173	2203-000254	C210	"C-CERAMIC,CHIP,10nF,10%,16V,X7R,TP,1005"	CL05B103KONC
174	2203-000254	C238	"C-CERAMIC,CHIP,10nF,10%,16V,X7R,TP,1005"	CL05B103KONC
175	2203-000254	C307	"C-CERAMIC,CHIP,10nF,10%,16V,X7R,TP,1005"	CL05B103KONC
176	2203-000254	C309	"C-CERAMIC,CHIP,10nF,10%,16V,X7R,TP,1005"	CL05B103KONC
177	2203-000254	C313	"C-CERAMIC,CHIP,10nF,10%,16V,X7R,TP,1005"	CL05B103KONC
178	2203-000254	C319	"C-CERAMIC,CHIP,10nF,10%,16V,X7R,TP,1005"	CL05B103KONC
179	2203-000254	C326	"C-CERAMIC,CHIP,10nF,10%,16V,X7R,TP,1005"	CL05B103KONC
180	2203-000254	C331	"C-CERAMIC,CHIP,10nF,10%,16V,X7R,TP,1005"	CL05B103KONC
181	2203-000254	C335	"C-CERAMIC,CHIP,10nF,10%,16V,X7R,TP,1005"	CL05B103KONC
182	2203-000254	C354	"C-CERAMIC,CHIP,10nF,10%,16V,X7R,TP,1005"	CL05B103KONC
183	2203-000254	C434	"C-CERAMIC,CHIP,10nF,10%,16V,X7R,TP,1005"	CL05B103KONC
184	2203-000254	C440	"C-CERAMIC,CHIP,10nF,10%,16V,X7R,TP,1005"	CL05B103KONC
185	2203-000254	C449	"C-CERAMIC,CHIP,10nF,10%,16V,X7R,TP,1005"	CL05B103KONC
186	2203-000254	C536	"C-CERAMIC,CHIP,10nF,10%,16V,X7R,TP,1005"	CL05B103KONC
187	2203-000254	C587	"C-CERAMIC,CHIP,10nF,10%,16V,X7R,TP,1005"	CL05B103KONC
188	2203-000254	C712	"C-CERAMIC,CHIP,10nF,10%,16V,X7R,TP,1005"	CL05B103KONC
189	2203-000254	C725	"C-CERAMIC,CHIP,10nF,10%,16V,X7R,TP,1005"	CL05B103KONC
190	2203-000254	C726	"C-CERAMIC,CHIP,10nF,10%,16V,X7R,TP,1005"	CL05B103KONC
191	2203-000254	C744	"C-CERAMIC,CHIP,10nF,10%,16V,X7R,TP,1005"	CL05B103KONC
192	2203-000254	C745	"C-CERAMIC,CHIP,10nF,10%,16V,X7R,TP,1005"	CL05B103KONC
	2203-000254	C762	"C-CERAMIC,CHIP,10nF,10%,16V,X7R,TP,1005"	CL05B103KONC
193	2203-000278	C206	"C-CERAMIC,CHIP,0.01nF,0.5pF,50V,NP0,1005"	CL05C100CBNC
194	2203-000278	C239	"C-CERAMIC,CHIP,0.01nF,0.5pF,50V,NP0,1005"	CL05C100CBNC
195	2203-000359	C212	"C-CERAMIC,CHIP,0.15nF,5%,50V,NP0,TP,1005"	CL05C151JBNC
196	2203-000386	C235	"C-CERAMIC,CHIP,0.015nF,5%,50V,NP0,1005"	CL05C150JBNC
197	2203-000438	C138	"C-CERAMIC,CHIP,1nF,10%,50V,X7R,TP,1005"	CL05B102KBNC
198	2203-000438	C211	"C-CERAMIC,CHIP,1nF,10%,50V,X7R,TP,1005"	CL05B102KBNC
199	2203-000438	C221	"C-CERAMIC,CHIP,1nF,10%,50V,X7R,TP,1005"	CL05B102KBNC
200	2203-000438	C227	"C-CERAMIC,CHIP,1nF,10%,50V,X7R,TP,1005"	CL05B102KBNC
201	2203-000438	C229	"C-CERAMIC,CHIP,1nF,10%,50V,X7R,TP,1005"	CL05B102KBNC
202	2203-000438	C230	"C-CERAMIC,CHIP,1nF,10%,50V,X7R,TP,1005"	CL05B102KBNC
203	2203-000438	C240	"C-CERAMIC,CHIP,1nF,10%,50V,X7R,TP,1005"	CL05B102KBNC
204	2203-000438	C261	"C-CERAMIC,CHIP,1nF,10%,50V,X7R,TP,1005"	CL05B102KBNC

NO	SEC CODE	Reference	Part Description	Vendor Part No.
205	2203-000438	C556	"C-CERAMIC,CHIP,1nF,10%,50V,X7R,TP,1005"	CL05B102KBNC
206	2203-000438	C557	"C-CERAMIC,CHIP,1nF,10%,50V,X7R,TP,1005"	CL05B102KBNC
207	2203-000438	C562	"C-CERAMIC,CHIP,1nF,10%,50V,X7R,TP,1005"	CL05B102KBNC
208	2203-000438	C580	"C-CERAMIC,CHIP,1nF,10%,50V,X7R,TP,1005"	CL05B102KBNC
209	2203-000466	C575	"C-CERAMIC,CHIP,0.001nF,0.25pF,50V,NP0,1005"	CL05C010CBNC
210	2203-000468	C747	"C-CERAMIC,CHIP,0.001nF,0.25pF,50V,NP0,1608"	CL10C010CBNC
211	2203-000585	C112	"C-CERAMIC,CHIP,220pF,10%,50V,X7R,TP,1005"	C1005X7R1H221KT
212	2203-000628	C237	"C-CERAMIC,CHIP,0.022nF,5%,50V,NP0,TP,1005"	CL05C220JBNC
213	2203-000628	C400	"C-CERAMIC,CHIP,0.022nF,5%,50V,NP0,TP,1005"	CL05C220JBNC
214	2203-000628	C401	"C-CERAMIC,CHIP,0.022nF,5%,50V,NP0,TP,1005"	CL05C220JBNC
215	2203-000679	C200	"C-CERAMIC,CHIP,0.027nF,5%,50V,NP0,TP,1005"	CL05C270JBNC
216	2203-000679	C232	"C-CERAMIC,CHIP,0.027nF,5%,50V,NP0,TP,1005"	CL05C270JBNC
217	2203-000679	C262	"C-CERAMIC,CHIP,0.027nF,5%,50V,NP0,TP,1005"	CL05C270JBNC
218	2203-000679	C540	"C-CERAMIC,CHIP,0.027nF,5%,50V,NP0,TP,1005"	CL05C270JBNC
219	2203-000679	C555	"C-CERAMIC,CHIP,0.027nF,5%,50V,NP0,TP,1005"	CL05C270JBNC
220	2203-000679	C569	"C-CERAMIC,CHIP,0.027nF,5%,50V,NP0,TP,1005"	CL05C270JBNC
221	2203-000679	C586	"C-CERAMIC,CHIP,0.027nF,5%,50V,NP0,TP,1005"	CL05C270JBNC
222	2203-000679	C740	"C-CERAMIC,CHIP,0.027nF,5%,50V,NP0,TP,1005"	CL05C270JBNC
223	2203-000679	C741	"C-CERAMIC,CHIP,0.027nF,5%,50V,NP0,TP,1005"	CL05C270JBNC
366	2203-000679	C743	"C-CERAMIC,CHIP,0.027nF,5%,50V,NP0,TP,1005"	CL05C270JBNC
	2203-000679	C770	"C-CERAMIC,CHIP,0.027nF,5%,50V,NP0,TP,1005"	CL05C270JBNC
224	2203-000696	C582	"C-CERAMIC,CHIP,0.002nF,0.25pF,50V,NP0,1005"	CL05C020CBNC
225	2203-000812	C143	"C-CERAMIC,CHIP,0.033nF,5%,50V,NP0,TP,1005"	CL05C330JBNC
226	2203-000812	C204	"C-CERAMIC,CHIP,0.033nF,5%,50V,NP0,TP,1005"	CL05C330JBNC
227	2203-000812	C217	"C-CERAMIC,CHIP,0.033nF,5%,50V,NP0,TP,1005"	CL05C330JBNC
228	2203-000812	C234	"C-CERAMIC,CHIP,0.033nF,5%,50V,NP0,TP,1005"	CL05C330JBNC
229	2203-000812	C263	"C-CERAMIC,CHIP,0.033nF,5%,50V,NP0,TP,1005"	CL05C330JBNC
230	2203-000812	C264	"C-CERAMIC,CHIP,0.033nF,5%,50V,NP0,TP,1005"	CL05C330JBNC
231	2203-000812	C310	"C-CERAMIC,CHIP,0.033nF,5%,50V,NP0,TP,1005"	CL05C330JBNC
232	2203-000812	C311	"C-CERAMIC,CHIP,0.033nF,5%,50V,NP0,TP,1005"	CL05C330JBNC
233	2203-000812	C312	"C-CERAMIC,CHIP,0.033nF,5%,50V,NP0,TP,1005"	CL05C330JBNC
234	2203-000812	C327	"C-CERAMIC,CHIP,0.033nF,5%,50V,NP0,TP,1005"	CL05C330JBNC
235	2203-000812	C330	"C-CERAMIC,CHIP,0.033nF,5%,50V,NP0,TP,1005"	CL05C330JBNC
236	2203-000812	C437	"C-CERAMIC,CHIP,0.033nF,5%,50V,NP0,TP,1005"	CL05C330JBNC
237	2203-000812	C438	"C-CERAMIC,CHIP,0.033nF,5%,50V,NP0,TP,1005"	CL05C330JBNC
238	2203-000812	C439	"C-CERAMIC,CHIP,0.033nF,5%,50V,NP0,TP,1005"	CL05C330JBNC
239	2203-000812	C441	"C-CERAMIC,CHIP,0.033nF,5%,50V,NP0,TP,1005"	CL05C330JBNC
240	2203-000812	C442	"C-CERAMIC,CHIP,0.033nF,5%,50V,NP0,TP,1005"	CL05C330JBNC
241	2203-000812	C443	"C-CERAMIC,CHIP,0.033nF,5%,50V,NP0,TP,1005"	CL05C330JBNC
242	2203-000812	C448	"C-CERAMIC,CHIP,0.033nF,5%,50V,NP0,TP,1005"	CL05C330JBNC
243	2203-000812	C460	"C-CERAMIC,CHIP,0.033nF,5%,50V,NP0,TP,1005"	CL05C330JBNC
244	2203-000812	C758	"C-CERAMIC,CHIP,0.033nF,5%,50V,NP0,TP,1005"	CL05C330JBNC

NO	SEC CODE	Reference	Part Description	Vendor Part No.
	2203-000812	C763	"C-CERAMIC,CHIP,0.033nF,5%,50V,NP0,TP,1005"	CL05C330JBNC
245	2203-000854	C244	"C-CERAMIC,CHIP,0.039nF,5%,50V,NP0,TP,1005"	CL05C390JBNC
246	2203-000854	C698	"C-CERAMIC,CHIP,0.039nF,5%,50V,NP0,TP,1005"	CL05C390JBNC
247	2203-000854	C699	"C-CERAMIC,CHIP,0.039nF,5%,50V,NP0,TP,1005"	CL05C390JBNC
248	2203-005052	C213	"C-CERAMIC,CHIP,0.0033nF,50V,NP0,TP,1005"	CL05C3R3CBNC
249	2203-001020	C538	"C-CERAMIC,CHIP,0.004nF,0.25pF,50V,NP0,1608"	CM105CG4R0C50AT
250	2203-001153	C215	"C-CERAMIC,CHIP,0.068nF,5%,50V,NP0,TP,1005"	CL05C680JBNC
251	2203-001153	C494	"C-CERAMIC,CHIP,0.068nF,5%,50V,NP0,TP,1005"	CL05C680JBNC
252	2203-002525	C126	"C-CERAMIC,CHIP,0.56nF,10%,50V,X7R,TP,1005"	C1005X7R1H561KT
253	2203-002525	C137	"C-CERAMIC,CHIP,0.56nF,10%,50V,X7R,TP,1005"	C1005X7R1H561KT
254	2203-002525	C481	"C-CERAMIC,CHIP,0.56nF,10%,50V,X7R,TP,1005"	C1005X7R1H561KT
255	2203-002668	C214	"C-CERAMIC,CHIP,0.0005nF,0.1pF,50V,1005"	CL05C0R5BBNC
256	2203-003054	C329	"C-CERAMIC,CHIP,0.009nF,0.25pF,50V,1005"	C1005C0G1H090CT
257	2203-003054	C444	"C-CERAMIC,CHIP,0.009nF,0.25pF,50V,1005"	C1005C0G1H090CT
258	2203-003054	C445	"C-CERAMIC,CHIP,0.009nF,0.25pF,50V,1005"	C1005C0G1H090CT
259	2203-003054	C539	"C-CERAMIC,CHIP,0.009nF,0.25pF,50V,1005"	C1005C0G1H090CT
260	2203-003054	C757	"C-CERAMIC,CHIP,0.009nF,0.25pF,50V,1005"	C1005C0G1H090CT
261	2203-005050	C600	"C-CERAMIC,CHIP,0.0018nF,0.25pF,50V,1005"	CL05C1R8CBNC
262	2203-005061	C106	"C-CERAMIC,CHIP,100nF,+80-20%,16V,1005"	C1005Y5V1C104ZT
263	2203-005061	C107	"C-CERAMIC,CHIP,100nF,+80-20%,16V,1005"	C1005Y5V1C104ZT
264	2203-000585	C110	"C-CERAMIC,CHIP,220pF,+80-20%,16V,1005"	C1005Y5V1C224ZT
265	2203-000585	C111	"C-CERAMIC,CHIP,220pF,+80-20%,16V,1005"	C1005Y5V1C224ZT
266	2203-000585	C114	"C-CERAMIC,CHIP,220pF,+80-20%,16V,1005"	C1005Y5V1C224ZT
267	2203-005061	C301	"C-CERAMIC,CHIP,100nF,+80-20%,16V,1005"	C1005Y5V1C104ZT
268	2203-005061	C332	"C-CERAMIC,CHIP,100nF,+80-20%,16V,1005"	C1005Y5V1C104ZT
269	2203-005061	C409	"C-CERAMIC,CHIP,100nF,+80-20%,16V,1005"	C1005Y5V1C104ZT
270	2203-005061	C427	"C-CERAMIC,CHIP,100nF,+80-20%,16V,1005"	C1005Y5V1C104ZT
271	2203-005061	C534	"C-CERAMIC,CHIP,100nF,+80-20%,16V,1005"	C1005Y5V1C104ZT
272	2203-005061	C545	"C-CERAMIC,CHIP,100nF,+80-20%,16V,1005"	C1005Y5V1C104ZT
273	2203-005061	C578	"C-CERAMIC,CHIP,100nF,+80-20%,16V,1005"	C1005Y5V1C104ZT
274	2203-005061	C588	"C-CERAMIC,CHIP,100nF,+80-20%,16V,1005"	C1005Y5V1C104ZT
275	2203-005061	C597	"C-CERAMIC,CHIP,100nF,+80-20%,16V,1005"	C1005Y5V1C104ZT
276	2203-005061	C701	"C-CERAMIC,CHIP,100nF,+80-20%,16V,1005"	C1005Y5V1C104ZT
277	2203-005061	C706	"C-CERAMIC,CHIP,100nF,+80-20%,16V,1005"	C1005Y5V1C104ZT
278	2203-005061	C711	"C-CERAMIC,CHIP,100nF,+80-20%,16V,1005"	C1005Y5V1C104ZT
279	2203-005065	C108	"C-CERAMIC,CHIP,1000nF,+80-20%,10V,1608"	GRM39Y5V105Z10PT
280	2203-005065	C125	"C-CERAMIC,CHIP,1000nF,+80-20%,10V,1608"	GRM39Y5V105Z10PT
281	2203-005065	C318	"C-CERAMIC,CHIP,1000nF,+80-20%,10V,1608"	GRM39Y5V105Z10PT
282	2203-005065	C403	"C-CERAMIC,CHIP,1000nF,+80-20%,10V,1608"	GRM39Y5V105Z10PT
283	2203-005065	C431	"C-CERAMIC,CHIP,1000nF,+80-20%,10V,1608"	GRM39Y5V105Z10PT
284	2203-005065	C705	"C-CERAMIC,CHIP,1000nF,+80-20%,10V,1608"	GRM39Y5V105Z10PT
285	2203-005065	C748	"C-CERAMIC,CHIP,1000nF,+80-20%,10V,1608"	GRM39Y5V105Z10PT

NO	SEC CODE	Reference	Part Description	Vendor Part No.
286	2203-005065	C749	"C-CERAMIC,CHIP,1000nF,+80-20%,10V,1608"	GRM39Y5V105Z10PT
287	2203-005234	C596	"C-CERAMIC,CHIP,0.0012nF,0.25pF,50V,1005"	CL05C1R2CBNC
288	2203-005382	C248	"C-CERAMIC,CHIP,0.006nF,0.1pF,50V,1005"	C1005C0G1H060BT
289	2203-005383	C752	"C-CERAMIC,CHIP,7pF,0.1pF,50V,NPO,TP,1005"	C1005C0G1H070BT
290	2203-005383	C753	"C-CERAMIC,CHIP,7pF,0.1pF,50V,NPO,TP,1005"	C1005C0G1H070BT
291	2203-005383	C754	"C-CERAMIC,CHIP,7pF,0.1pF,50V,NPO,TP,1005"	C1005C0G1H070BT
292	2203-005383	C755	"C-CERAMIC,CHIP,7pF,0.1pF,50V,NPO,TP,1005"	C1005C0G1H070BT
293	2203-005446	C721	"C-CERAMIC,CHIP,0.0027nF,0.1pF,50V,1005"	C1005C0G1H2R7BT
294	2203-005480	C450	"C-CERAMIC,CHIP,33nF,10%,10V,X7R,TP,1005"	C1005X7R1C333KT
295	2203-005480	C451	"C-CERAMIC,CHIP,33nF,10%,10V,X7R,TP,1005"	C1005X7R1C333KT
296	2203-005481	C459	"C-CERAMIC,CHIP,47nF,10%,10V,X7R,TP,1005"	C1005X7R1A473KT
297	2203-005482	C746	"C-CERAMIC,CHIP,100nF,10%,10V,X5R,TP,1005"	GRM36X5R104K10PT
298	2203-005482	C751	"C-CERAMIC,CHIP,100nF,10%,10V,X5R,TP,1005"	GRM36X5R104K10PT
299	2203-005503	C456	"C-CERAMIC,CHIP,0.18nF,5%,25V,NPO,TP,1005"	C1005CH1E181J
300	2203-005503	C457	"C-CERAMIC,CHIP,0.18nF,5%,25V,NPO,TP,1005"	C1005CH1E181J
301	2203-005552	C727	"C-CERAMIC,CHIP,0.0022nF,0.1pF,50V,NPO,1005"	C1005C0G1H2R2BT
302	2301-001232	C202	"C-FILM,CHIP,470pF,5%,50V,TP,2x1.25x0.8mm"	ECHU1H391JX5
303	2203-000609	C203	"C-FILM,CHIP,22nF,5%,16V,TP,2012"	ECHU1C682JX5
304	2404-001020	C710	"C-TA,CHIP,10uF,20%,10V,GP,TP,3216"	TAJA106M010R
305	2404-001083	C249	"C-TA,CHIP,220uF,20%,6.3V,LZ,TP,7132"	F750J227MCCGZT
306	2404-001101	C220	"C-TA,CHIP,1uF,20%,16V,GP,TP,2012"	TAJR105M016R
307	2404-001105	C105	"C-TA,CHIP,10UF,20%,6.3V,GP,TP,2012"	ECST0JZ106R
308	2404-001105	C117	"C-TA,CHIP,10UF,20%,6.3V,GP,TP,2012"	ECST0JZ106R
309	2404-001105	C124	"C-TA,CHIP,10UF,20%,6.3V,GP,TP,2012"	ECST0JZ106R
310	2404-001105	C145	"C-TA,CHIP,10UF,20%,6.3V,GP,TP,2012"	ECST0JZ106R
311	2404-001105	C306	"C-TA,CHIP,10UF,20%,6.3V,GP,TP,2012"	ECST0JZ106R
312	2404-001105	C328	"C-TA,CHIP,10UF,20%,6.3V,GP,TP,2012"	ECST0JZ106R
313	2404-001105	C535	"C-TA,CHIP,10UF,20%,6.3V,GP,TP,2012"	ECST0JZ106R
314	2404-001105	C708	"C-TA,CHIP,10UF,20%,6.3V,GP,TP,2012"	ECST0JZ106R
315	2404-001105	C750	"C-TA,CHIP,10UF,20%,6.3V,GP,TP,2012"	ECST0JZ106R
316	2404-001134	C436	"C-TA,CHIP,100UF,20%,6.3V,LZ,TP,4028"	595D107X06R3B2T
317	2404-001134	C579	"C-TA,CHIP,100UF,20%,6.3V,LZ,TP,4028"	595D107X06R3B2T
318	2404-001162	C446	"C-TA,CHIP,47uF,20%,4V,LZ,TP,3216"	F950G476MAAJZTQ2
319	2703-001178	L594	"INDUCTOR-SMD,3.3nH,0.3nH,1x0.5x0.5mm"	HK1005-3N3S-T
320	2703-001180	L211	"INDUCTOR-SMD,15nH,5%,1x0.5x0.5mm"	LL1005-FH15NJ
321	2703-001257	L599	"INDUCTOR-SMD,3.9nH,0.3nH,1.6x0.8x0.8mm"	HK1608-3N9S-T
322	2703-001293	L200	"INDUCTOR-SMD,82nH,5%,1.6x0.8x0.8mm"	HK1608-82NJ-T
323	2703-001514	L201	"INDUCTOR-SMD,68nH,5%,1.8x1.12x1.02mm"	0603CS-68NXJBC
324	2703-001545	L212	"INDUCTOR-SMD,47nH,5%,1.8x1.12x1.02mm"	0603CS-47NXJBC
325	2703-001545	L213	"INDUCTOR-SMD,47nH,5%,1.8x1.12x1.02mm"	0603CS-47NXJBC
326	2703-001708	L406	"INDUCTOR-SMD,5.6nH,10%,1.0x0.5x0.5mm"	HK1005-5N6K-T
327	2703-001735	L596	"INDUCTOR-SMD,3.9nH,10%,1x0.5x0.5mm"	HK1005-3N9K-T

NO	SEC CODE	Reference	Part Description	Vendor Part No.
328	2703-001750	L402	"INDUCTOR-SMD,2.2NH,0.3NH,1X0.5X0.5MM"	LL1005-FH2N2S
	2703-001752	U622	"INDUCTOR-SMD,39nH,5%,1.0x0.5x0.5mm"	LL1005-FH39NJ
330	2703-001786	L404	"INDUCTOR-SMD,10NH,5%,1.0X0.5X0.5MM"	LL1005-FH10NJ
331	2703-001943	L600	"INDUCTOR-SMD,10nH,5%,1.0x0.5x0.5mm"	HK1005-10NJ-T
332	2703-001949	L595	"INDUCTOR-SMD,4.7nH,10%,1.0x0.5x0.5mm"	HK1005-4N7K-T
333	2703-001950	L204	"INDUCTOR-SMD,12nH,10%,1.0x0.5x0.5mm"	HK1005-12NK-T
334	2703-001952	L209	"INDUCTOR-SMD,8.2nH,5%,1.0x0.5x0.5mm"	HK1005-8N2J-T
335	2703-001952	L597	"INDUCTOR-SMD,8.2nH,5%,1.0x0.5x0.5mm"	HK1005-8N2J-T
336	2703-001953	L218	"INDUCTOR-SMD,6.8nH,5%,1.0x0.5x0.5mm"	HK1005-6N8J-T
337	2801-003856	X1	"CRYSTAL-SMD,0.032786MHz,20ppm"	"MC-146(32.768KHZ,20P"
338	2806-001239	U200	"OSCILLATOR-VCO,1748MHZ,-,50ohm,TP,2.8V"	VOF1748C28KRF
339	2809-001237	U100	"OSCILLATOR-VCTCXO,13MHz,5ppm,10Kohm"	KT16-KEU30L-13.000M-T
340	2901-001116	E200	"FILTER-EMI SMD,50V,0.3A,-,470pF"	NFM2012R13C471R
341	2904-001325	F203	"FILTER-SAW,1.8425GHZ,75MHZ,+,-37.5MHZ"	B4215
342	2904-001325	F204	"FILTER-SAW,1.8425GHZ,75MHZ,1805-1880MHZ"	B4215
343	2904-001320	F200	"FILTER-SAW,225MHZ,0.16MHZ,0.7MS,TP"	855844
344	2909-001146	U203	"FILTER-DUPLEXER,942.5MHZ,897.5MHZ"	LMG002S-5008C
	3301-001362	L605	"CORE-FERRITE BEAD,AB,1kohm,1x0.5x0.5mm"	BLM10A102SGPT
345	3705-001226	CN1	"CONNECTOR-COAXIAL,JACK,75mohm,50ohm"	MHC-188
346	3709-001088	J402	"CONNECTOR-CARD EDGE,6P,2.54mm"	2-338063-2
347	3710-001105	M1	CONNECTOR-SOCKET	24-8005-002-100-867
348	3710-001595	J403	"IF CONNECTOR;18P,1R.0.5mm"	1004-0018-304
349	3722-001587	U400	"JACK-PHONE,6P,2.6PI,AG,BLK"	02-828DO-53BKA
350	4302-001119	BAT1	"BATTERY-LI(2ND),3V,0.1MAH"	RB414II06N
351	4709-001144	U318	"COUPLER-DIRECTION,897.5/1747.5MHZ"	LDC21897M19D-078
352	2007-000139	R745	"R-CHIP,220ohm,5%,1/16W,DA,TP,1005"	RK73K1ETP221J
353	2007-000139	R746	"R-CHIP,220ohm,5%,1/16W,DA,TP,1005"	RK73K1ETP221J
354	2007-000139	R747	"R-CHIP,220ohm,5%,1/16W,DA,TP,1005"	RK73K1ETP221J
355	2007-000139	R748	"R-CHIP,220ohm,5%,1/16W,DA,TP,1005"	RK73K1ETP221J
356	2203-002668	C242	"C-CERAMIC,CHIP,0.5pF,0.1pF,50V,TP,1005"	CL05C0R5BBNC
357	2703-002231	L201	"INDUCTOR-SMD,68NH,5%,1.6X0.8X0.8MM"	CIH10T68NJNC
358	2703-002209	L212	"INDUCTOR-SMD,47NH,5%,1.6X0.8X0.8MM"	CIH10T47NJNC
359	2703-002209	L213	"INDUCTOR-SMD,47NH,5%,1.6X0.8X0.8MM"	CIH10T47NJNC
360	N.C POINT	C201	N.C POINT	
361	N.C POINT	C413	N.C POINT	
362	N.C POINT	C704	N.C POINT	
363	N.C POINT	C714	N.C POINT	
364	N.C POINT	C717	N.C POINT	
365	N.C POINT	C728	N.C POINT	
367	N.C POINT	R436	N.C POINT	
368	N.C POINT	R448	N.C POINT	

3-2 Main Parts List Bottom

NO	SEC CODE	Reference	Part Description	Vendor Part No.
1	0407-001002	D302	"DIODE-ARRAY,DAN222,80V,300mA,CA2-3,EM3"	DAN222
2	0501-002011	Q300	"TR-SMALL SIGNAL,2SD2114K,NPN,200mW,SOT-23"	2SD2114KT146V
3	0504-001012	U209	"TR-DIGITAL,DTC114YE,NPN,150MW,10K/47K"	DTC114YE
4	0504-001058	U204	"TR-DIGITAL,RN4985,NPN/PNP,200mW,2.2Kohm"	RN4985
5	0504-001058	U492	"TR-DIGITAL,RN4985,NPN/PNP,200mW,2.2Kohm"	RN4985
6	0504-001058	U493	"TR-DIGITAL,RN4985,NPN/PNP,200mW,2.2Kohm"	RN4985
7	0601-001402	LED1	"LED,CHIP,RED/Y-GRN,1.2x1.5mm,660/570nm"	CL165HR/YG-D-T
8	0601-001547	LED2	"LED,CHIP,BLUE,1.1X0.8MM,485NM"	SLSNNBL102TS
9	0601-001094	D433	"LED,CHIP,Y-GRN,0.8x1.1mm,570nm"	SSCYG101TS
10	0601-001094	D434	"LED,CHIP,Y-GRN,0.8x1.1mm,570nm"	SSCYG101TS
11	0601-001094	D427	"LED,CHIP,Y-GRN,0.8x1.1mm,570nm"	SSCYG101TS
12	0601-001094	D428	"LED,CHIP,Y-GRN,0.8x1.1mm,570nm"	SSCYG101TS
13	0601-001094	D429	"LED,CHIP,Y-GRN,0.8x1.1mm,570nm"	SSCYG101TS
14	0601-001094	D430	"LED,CHIP,Y-GRN,0.8x1.1mm,570nm"	SSCYG101TS
15	0601-001094	D431	"LED,CHIP,Y-GRN,0.8x1.1mm,570nm"	SSCYG101TS
16	0601-001094	D432	"LED,CHIP,Y-GRN,0.8x1.1mm,570nm"	SSCYG101TS
17	1209-001379	U611	"IC-ETC, LINEAR,16P,3.4V,240MW"	HD155173ANPEL
18	1405-001093	D411	"VARISTOR,14V,20A,1x0.5x0.6mm"	VC040214X500R
19	1405-001093	D415	"VARISTOR,14V,20A,1x0.5x0.6mm"	VC040214X500R
20	2007-000139	R725	"R-CHIP,220ohm,5%,1/16W,DA,TP,1005"	RK73K1ETP221J
21	2007-000139	R573	"R-CHIP,220ohm,5%,1/16W,DA,TP,1005"	RK73K1ETP221J
22	2007-000139	R572	"R-CHIP,220ohm,5%,1/16W,DA,TP,1005"	RK73K1ETP221J
23	2007-000139	R574	"R-CHIP,220ohm,5%,1/16W,DA,TP,1005"	RK73K1ETP221J
24	2007-000143	R305	"R-CHIP,4.7Kohm,5%,1/16W,DA,TP,1005"	RK73K1ETP472J
25	2007-000148	R238	"R-CHIP,10Kohm,5%,1/16W,DA,TP,1005"	RK73K1ETP103J
26	2007-000148	R240	"R-CHIP,10Kohm,5%,1/16W,DA,TP,1005"	RK73K1ETP103J
27	2007-000148	R241	"R-CHIP,10Kohm,5%,1/16W,DA,TP,1005"	RK73K1ETP103J
28	2007-000148	R424	"R-CHIP,10Kohm,5%,1/16W,DA,TP,1005"	RK73K1ETP103J
29	2007-000148	R427	"R-CHIP,10Kohm,5%,1/16W,DA,TP,1005"	RK73K1ETP103J
30	2007-000148	R651	"R-CHIP,10Kohm,5%,1/16W,DA,TP,1005"	RK73K1ETP103J
31	2007-000162	R304	"R-CHIP,100Kohm,5%,1/16W,DA,TP,1005"	RK73K1ETP104J
32	2007-000162	R422	"R-CHIP,100Kohm,5%,1/16W,DA,TP,1005"	RK73K1ETP104J
33	2007-000162	R423	"R-CHIP,100Kohm,5%,1/16W,DA,TP,1005"	RK73K1ETP104J
34	2007-000982	R624	"R-CHIP,5.6Kohm,5%,1/16W,DA,TP,1005"	RK73K1ETP562J
35	2007-001301	R665	"R-CHIP,68ohm,5%,1/16W,DA,TP,1005"	ERJ2GEJ680X
36	2007-001301	R666	"R-CHIP,68ohm,5%,1/16W,DA,TP,1005"	ERJ2GEJ680X
37	2007-001306	R667	"R-CHIP,150ohm,5%,1/16W,DA,TP,1005"	RK73K1ETP151J
38	2007-007142	R617	"R-CHIP,10Kohm,1%,1/16W,DA,TP,1005"	RK73H1ETP1002F
39	2007-007142	R618	"R-CHIP,10Kohm,1%,1/16W,DA,TP,1005"	RK73H1ETP1002F
40	2007-007311	R626	"R-CHIP,22Kohm,1%,1/16W,DA,TP,1005"	RK73H1ETP2202F
41	2007-007771	R729	"R-CHIP,0OHM,5%,1/16W,DA,TP,1005"	ERJ2GE0R00L
42	2203-000654	C655	"C-CERAMIC,CHIP,270pF,10%,50V,X7R,TP,1005"	C1005X7R1H271KT

NO	SEC CODE	Reference	Part Description	Vendor Part No.
43	2203-000654	C585	"C-CERAMIC,CHIP,270pF,10%,50V,X7R,TP,1005"	C1005X7R1H271KT
44	2203-000438	C720	"C-CERAMIC,CHIP,1nF,10%,50V,X7R,TP,1005"	CL05B102KBNC
45	2203-000995	C713	"C-CERAMIC,CHIP,0.047nF,5%,50V,NP0,TP,1005"	CL05C470JBNC
46	2203-000812	C664	"C-CERAMIC,CHIP,0.033nF,5%,50V,NP0,TP,1005"	CL05C330JBNC
47	2203-000311	C657	"C-CERAMIC,CHIP,0.12nF,5%,50V,NP0,TP,1005"	CL05C121JANC
48	2203-000233	C658	"C-CERAMIC,CHIP,0.1nF,5%,50V,NP0,TP,1005"	CL05C101JBNC
49	2203-000679	C665	"C-CERAMIC,CHIP,0.027nF,5%,50V,NP0,TP,1005"	CL05C270JBNC
50	2203-000438	C270	"C-CERAMIC,CHIP,1nF,10%,50V,X7R,TP,1005"	CL05B102KBNC
51	2203-000679	C267	"C-CERAMIC,CHIP,0.027nF,5%,50V,NP0,TP,1005"	CL05C270JBNC
52	2203-000679	C269	"C-CERAMIC,CHIP,0.027nF,5%,50V,NP0,TP,1005"	CL05C270JBNC
53	2203-005061	C308	"C-CERAMIC,CHIP,100nF,+80-20%,16V,1005"	C1005Y5V1C104ZT
54	2203-005061	C418	"C-CERAMIC,CHIP,100nF,+80-20%,16V,1005"	C1005Y5V1C104ZT
55	2203-005061	C419	"C-CERAMIC,CHIP,100nF,+80-20%,16V,1005"	C1005Y5V1C104ZT
56	2203-005061	C420	"C-CERAMIC,CHIP,100nF,+80-20%,16V,1005"	C1005Y5V1C104ZT
57	2203-005061	C421	"C-CERAMIC,CHIP,100nF,+80-20%,16V,1005"	C1005Y5V1C104ZT
58	2203-005065	C411	"C-CERAMIC,CHIP,1000nF,+80-20%,10V,1608"	GRM39Y5V105Z10PT
59	2203-005065	C412	"C-CERAMIC,CHIP,1000nF,+80-20%,10V,1608"	GRM39Y5V105Z10PT
60	2203-005065	C415	"C-CERAMIC,CHIP,1000nF,+80-20%,10V,1608"	GRM39Y5V105Z10PT
61	2203-005065	C417	"C-CERAMIC,CHIP,1000nF,+80-20%,10V,1608"	GRM39Y5V105Z10PT
62	2203-005065	C422	"C-CERAMIC,CHIP,1000nF,+80-20%,10V,1608"	GRM39Y5V105Z10PT
63	2203-005065	C490	"C-CERAMIC,CHIP,1000nF,+80-20%,10V,1608"	GRM39Y5V105Z10PT
64	2203-005444	C404	"C-CERAMIC,CHIP,0.003nF,0.1pF,50V,NP0,1005"	C1005C0G1H030BT
65	2703-001723	L408	"INDUCTOR-SMD,33nH,5%,1.0x0.5x0.5mm"	HK1005-33NJ-T
66	2703-001723	L409	"INDUCTOR-SMD,33nH,5%,1.0x0.5x0.5mm"	HK1005-33NJ-T
67	3002-001098	BUZ300	"BUZZER-MAGNETIC,94dB,3V,150mA,2700Hz"	BRT-03S
68	N.C	R730	N.C POINT	
69	N.C	C715	N.C POINT	

4. Block Diagrams

4-1 Main Baseband

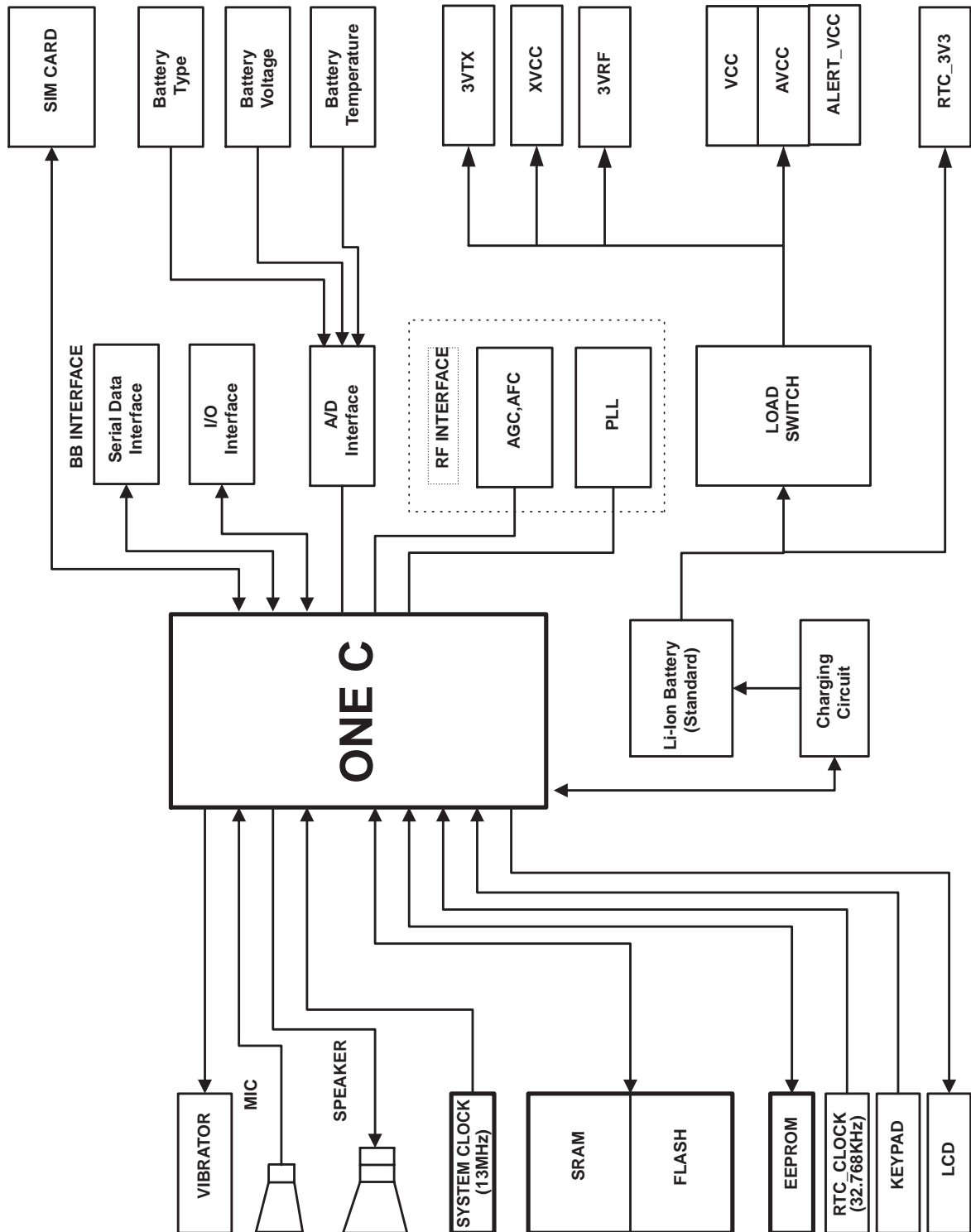

4-2 Main RF

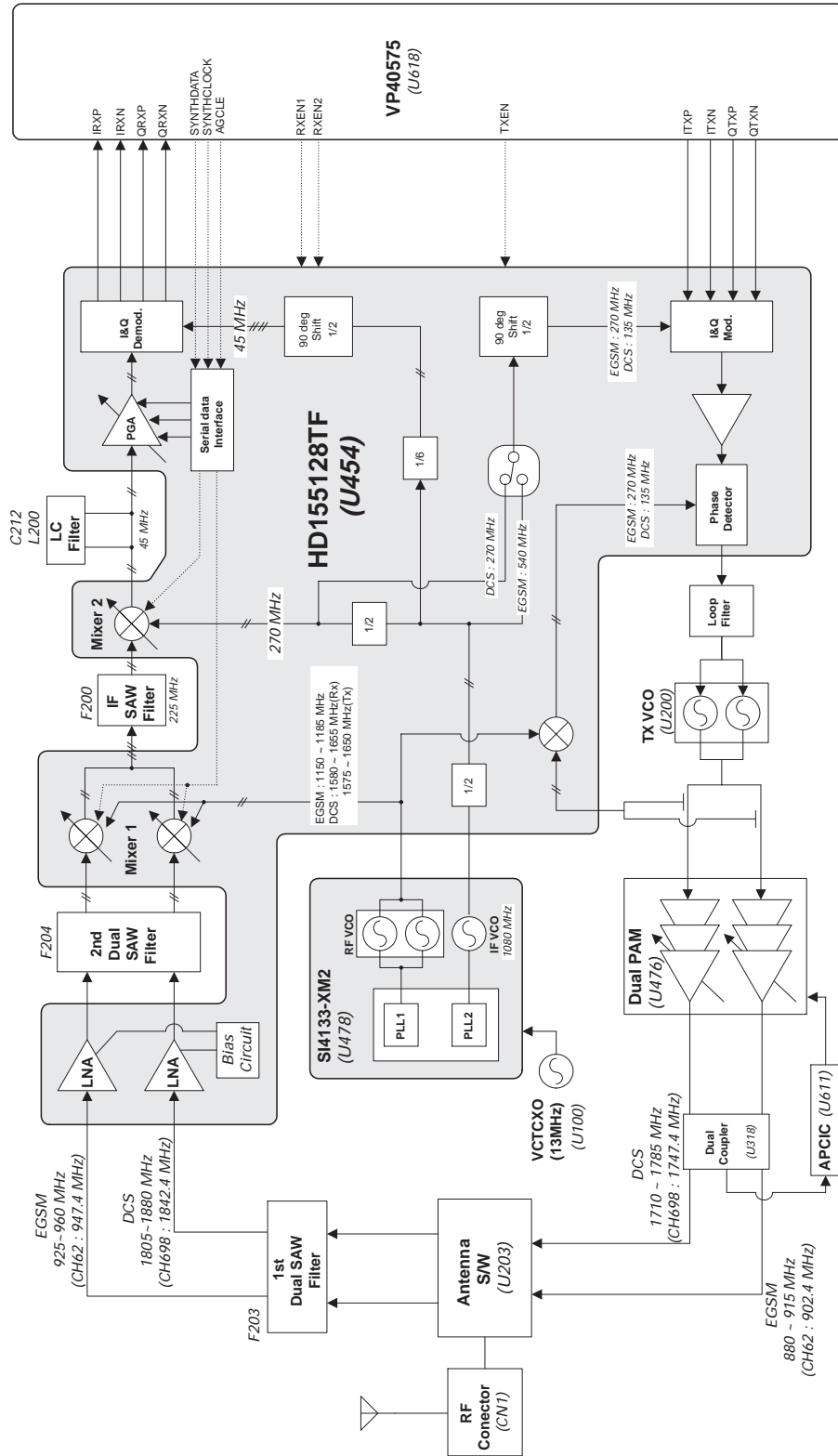

4-2-1 RF Transmit Part

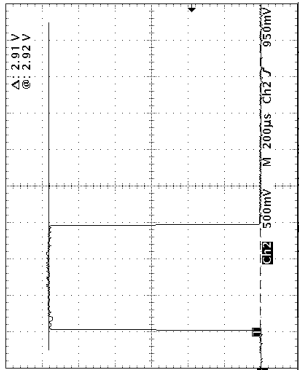

①

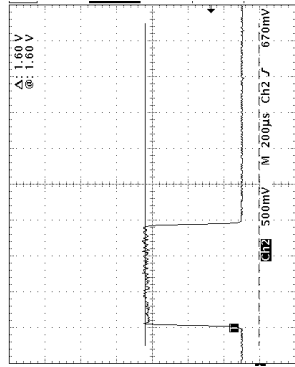

②

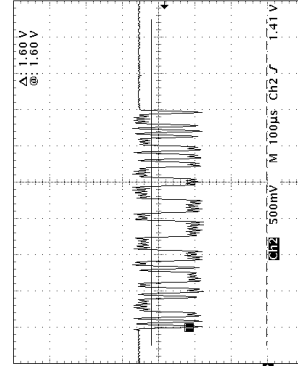

③

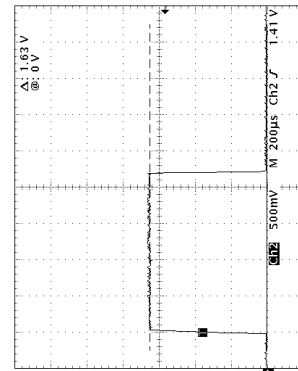
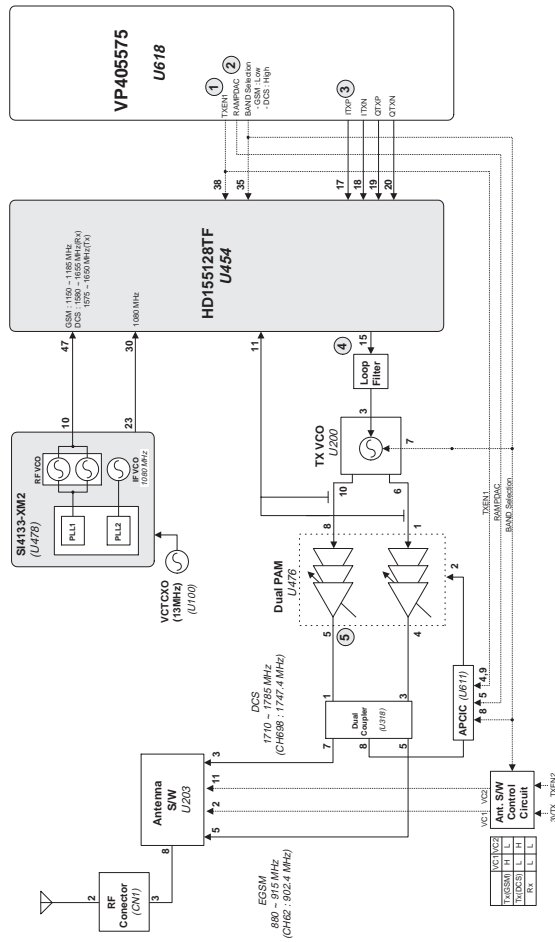

④

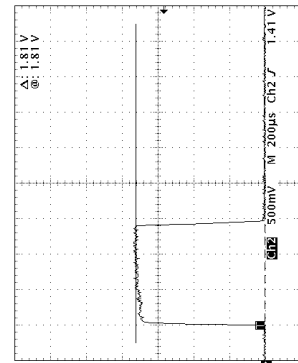

⑤

4-2-2 RF Receive Part

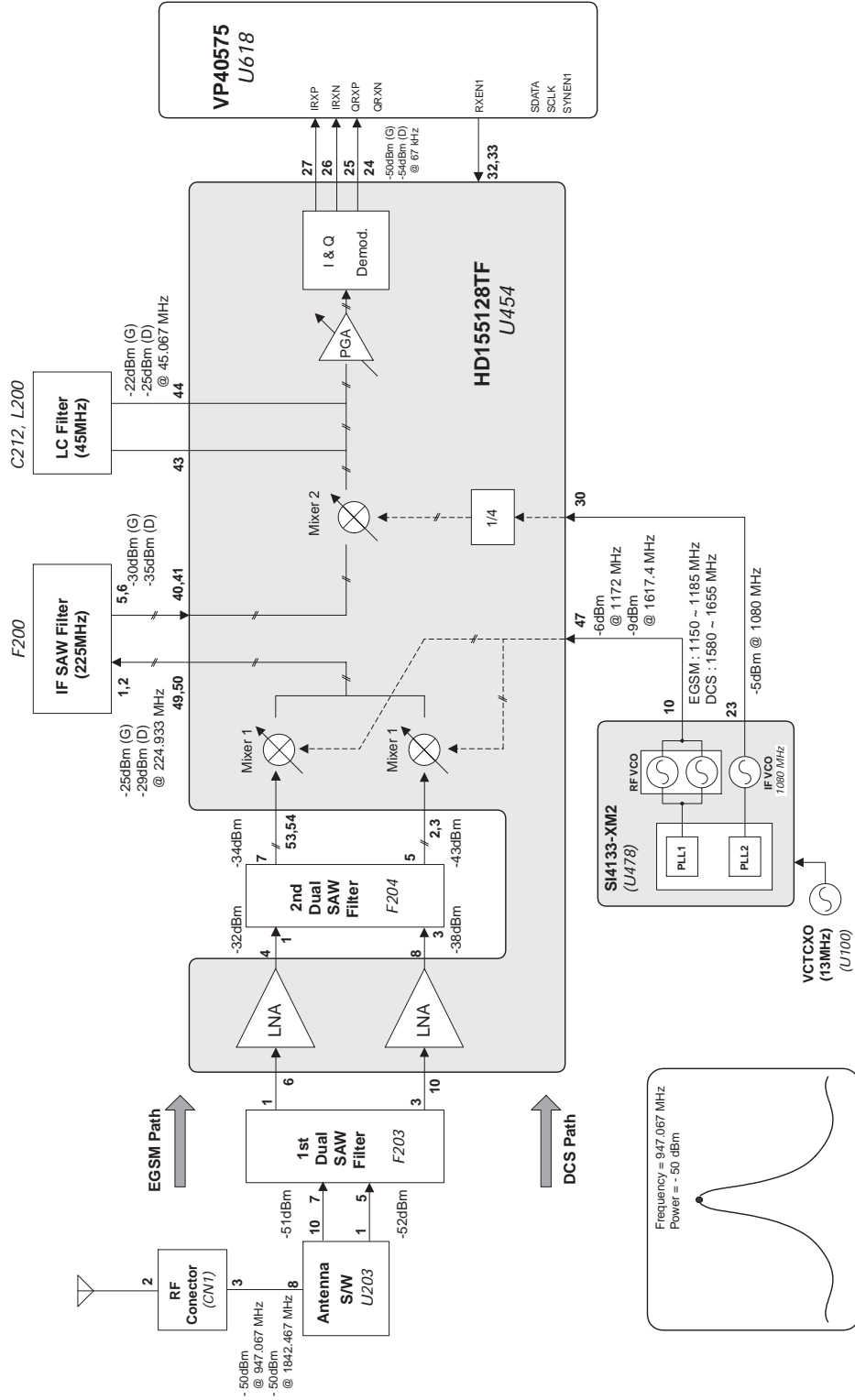

5. Flow Chart of Troubleshooting and Circuit Diagrams

5-1 Power ON

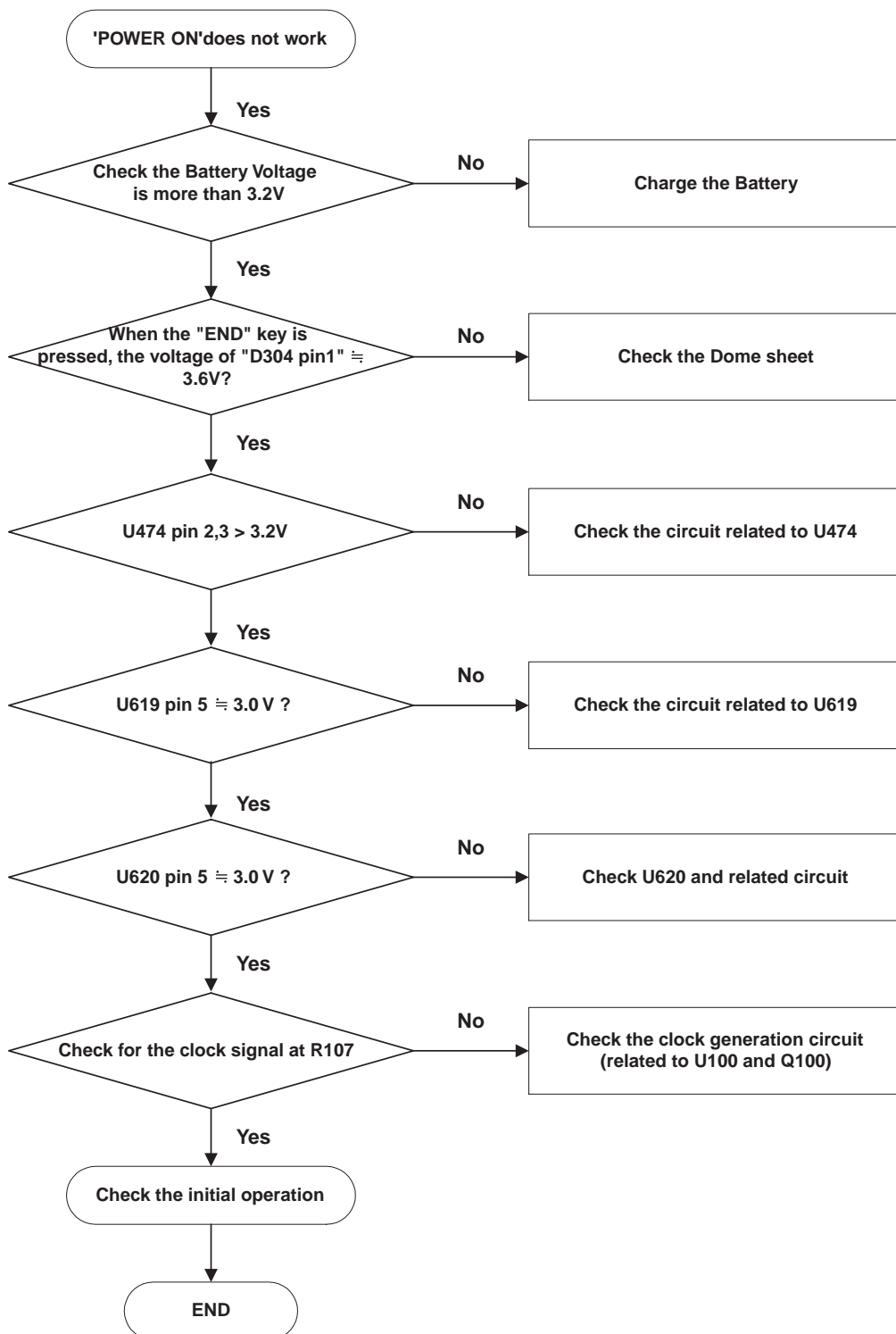

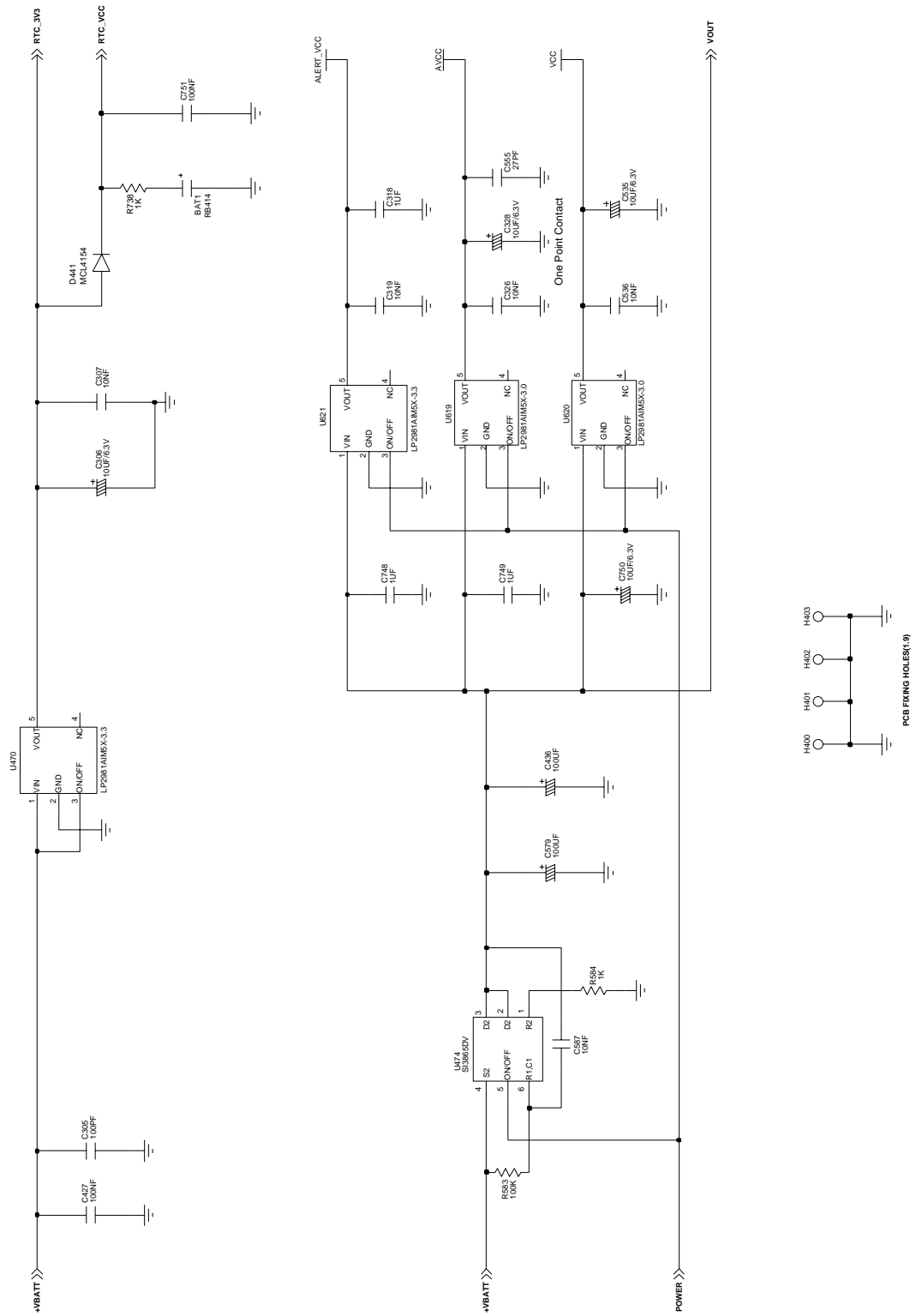

5-2 Initial

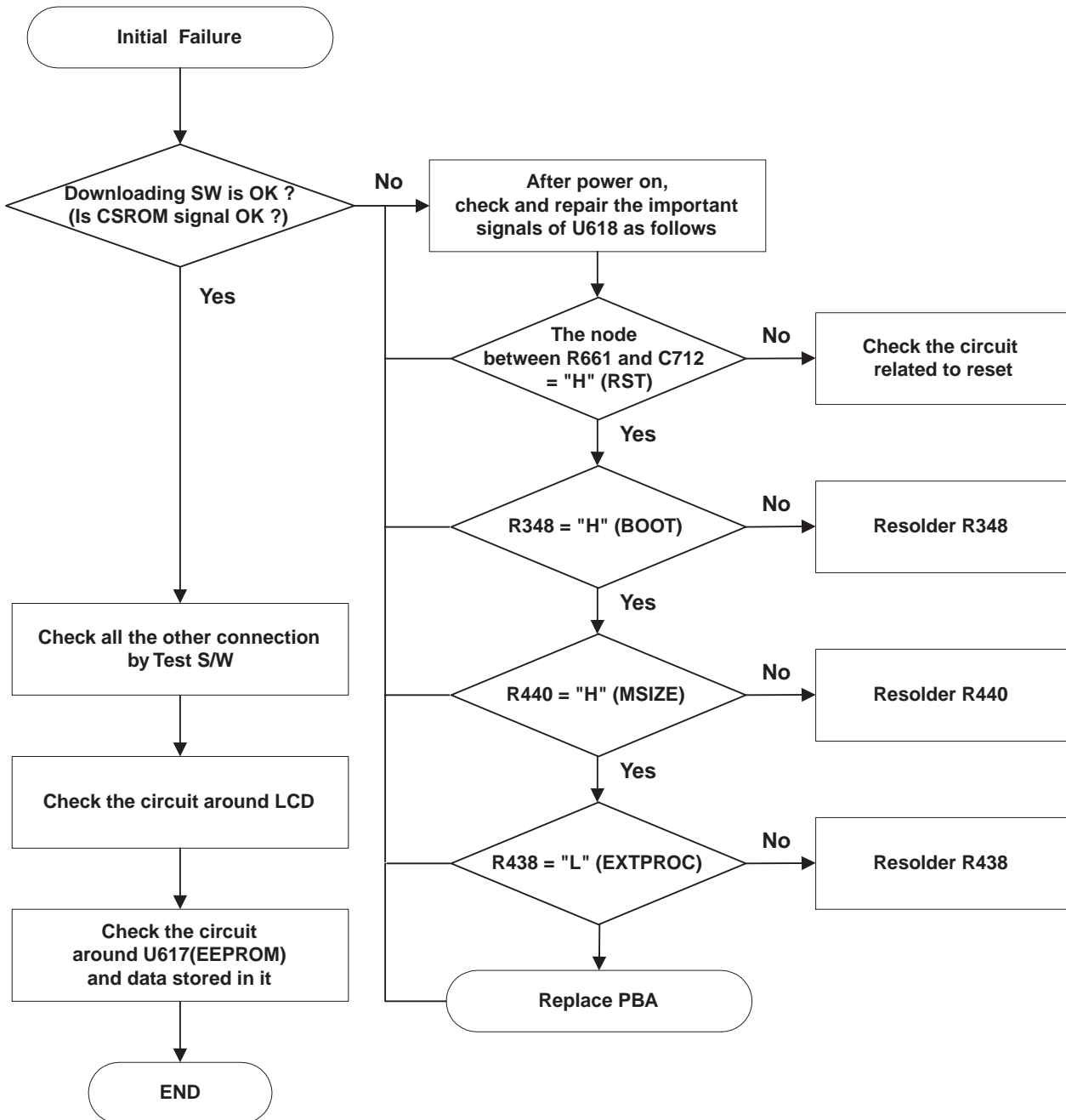

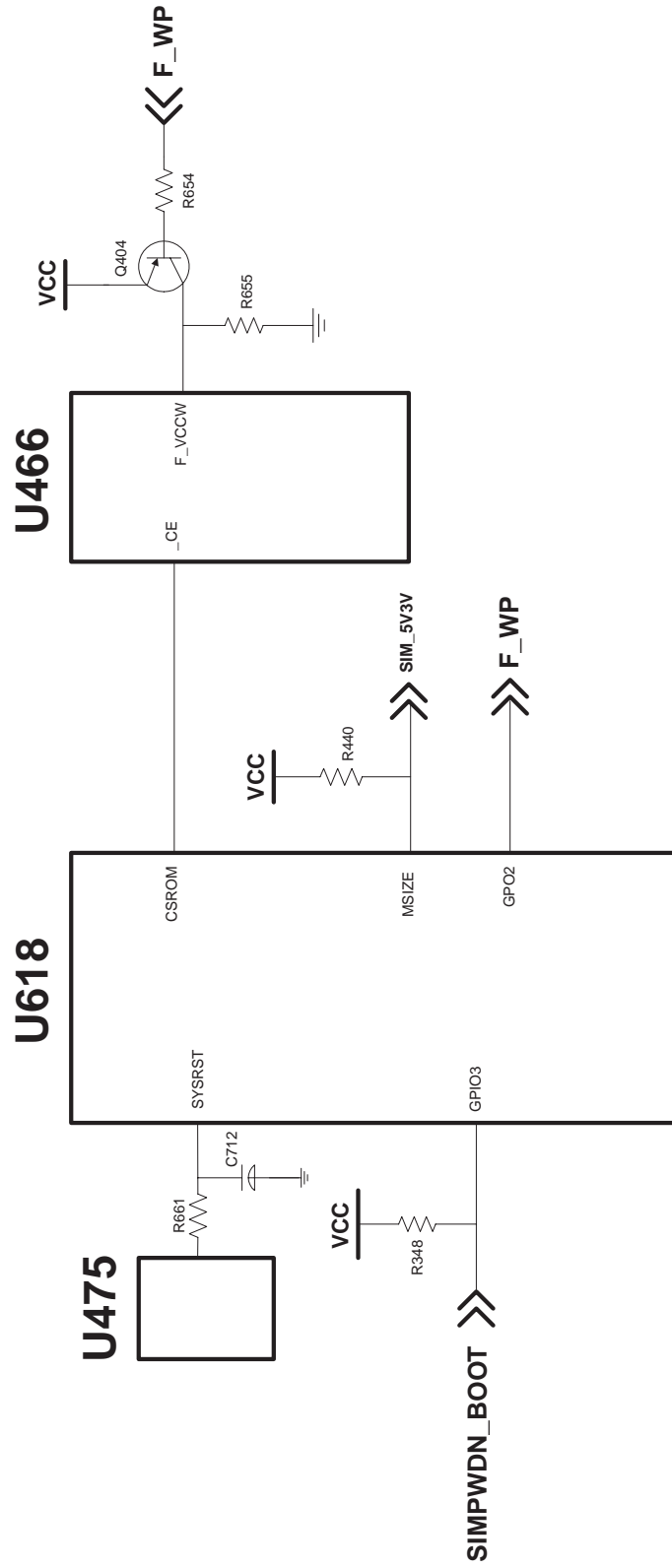

5-3 Charging Part

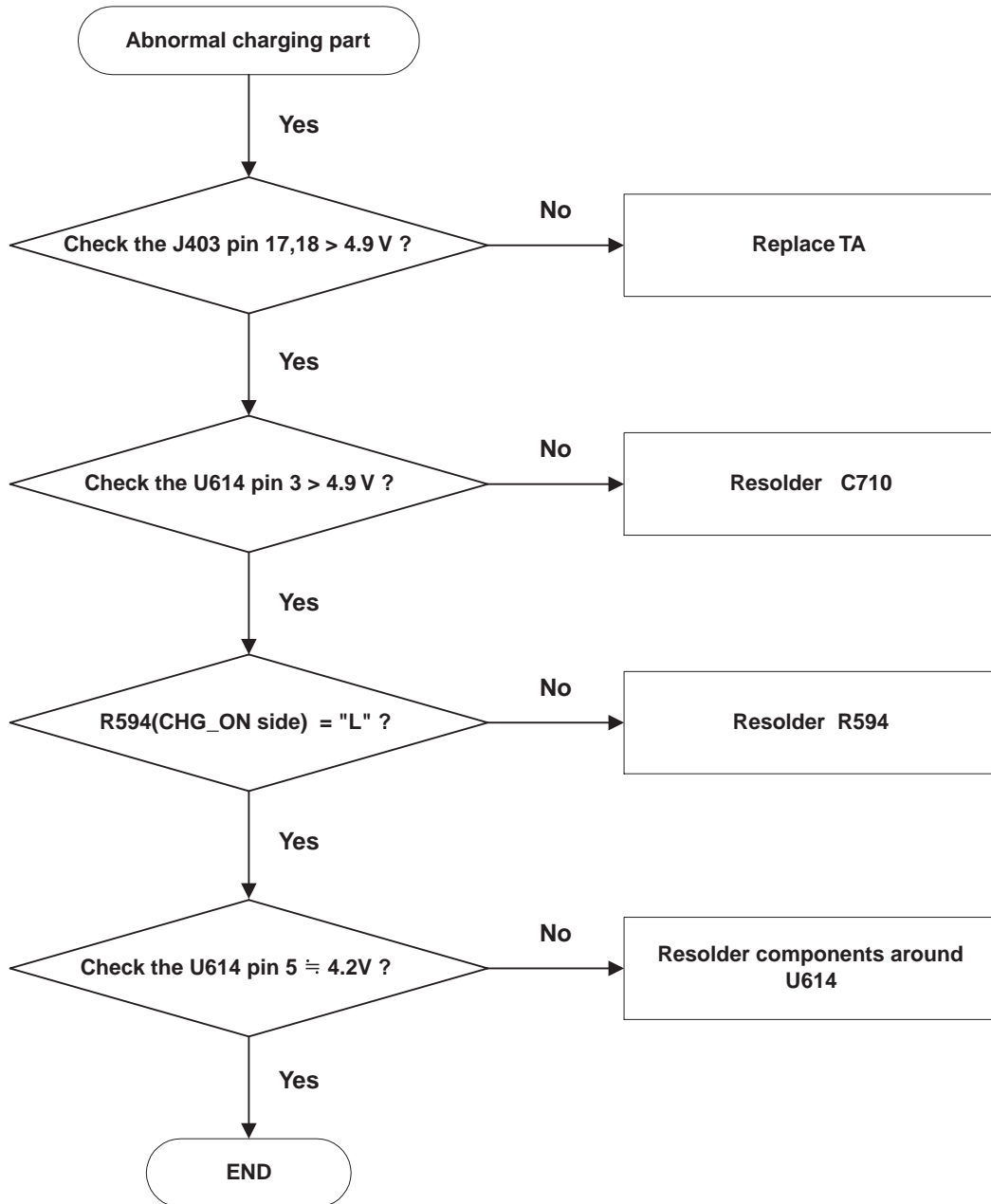

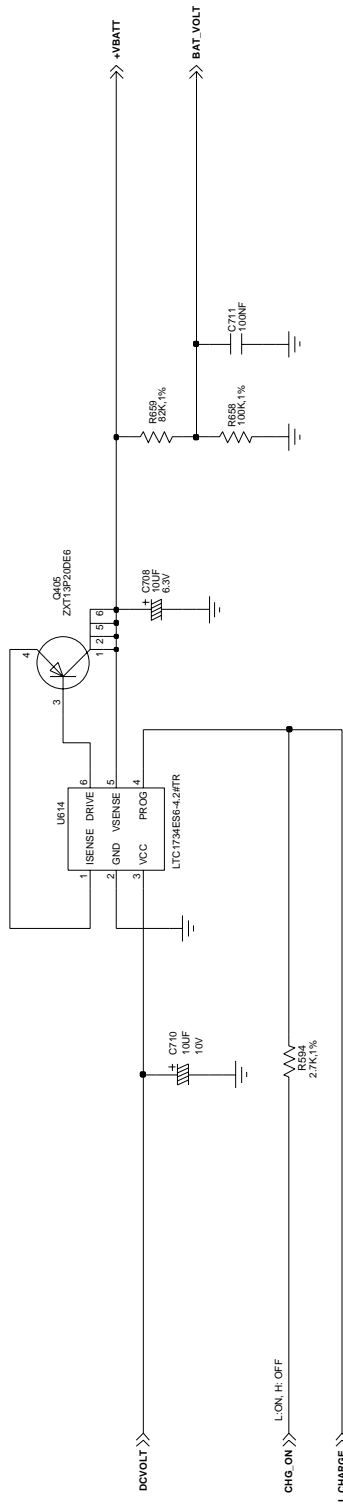

5-4 Sim Part

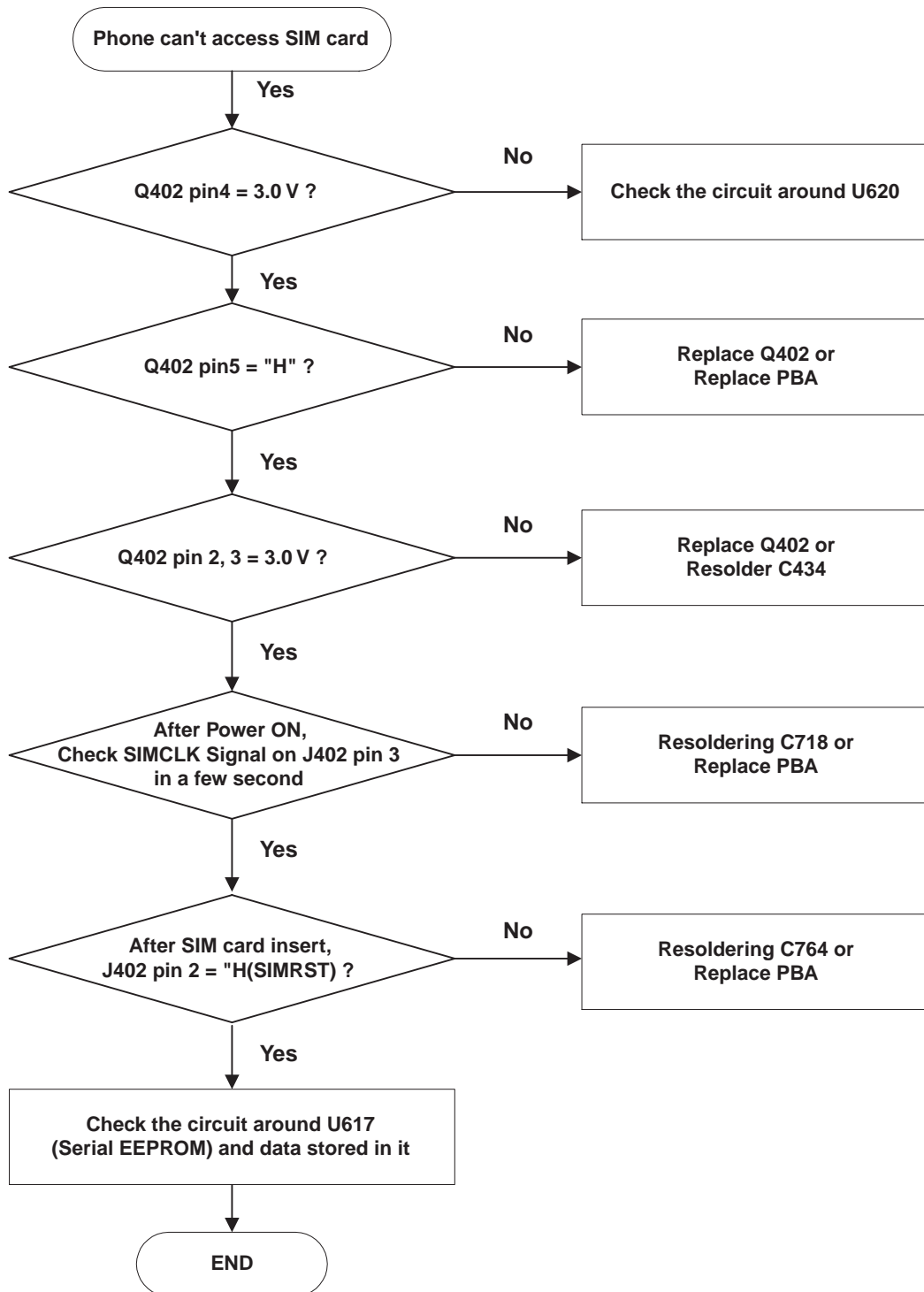

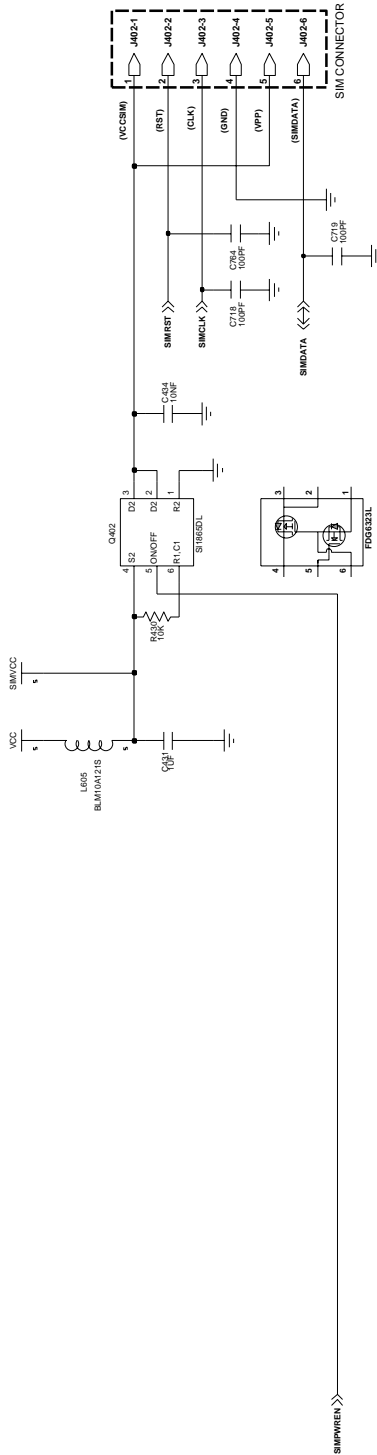

5-5 Microphone Part

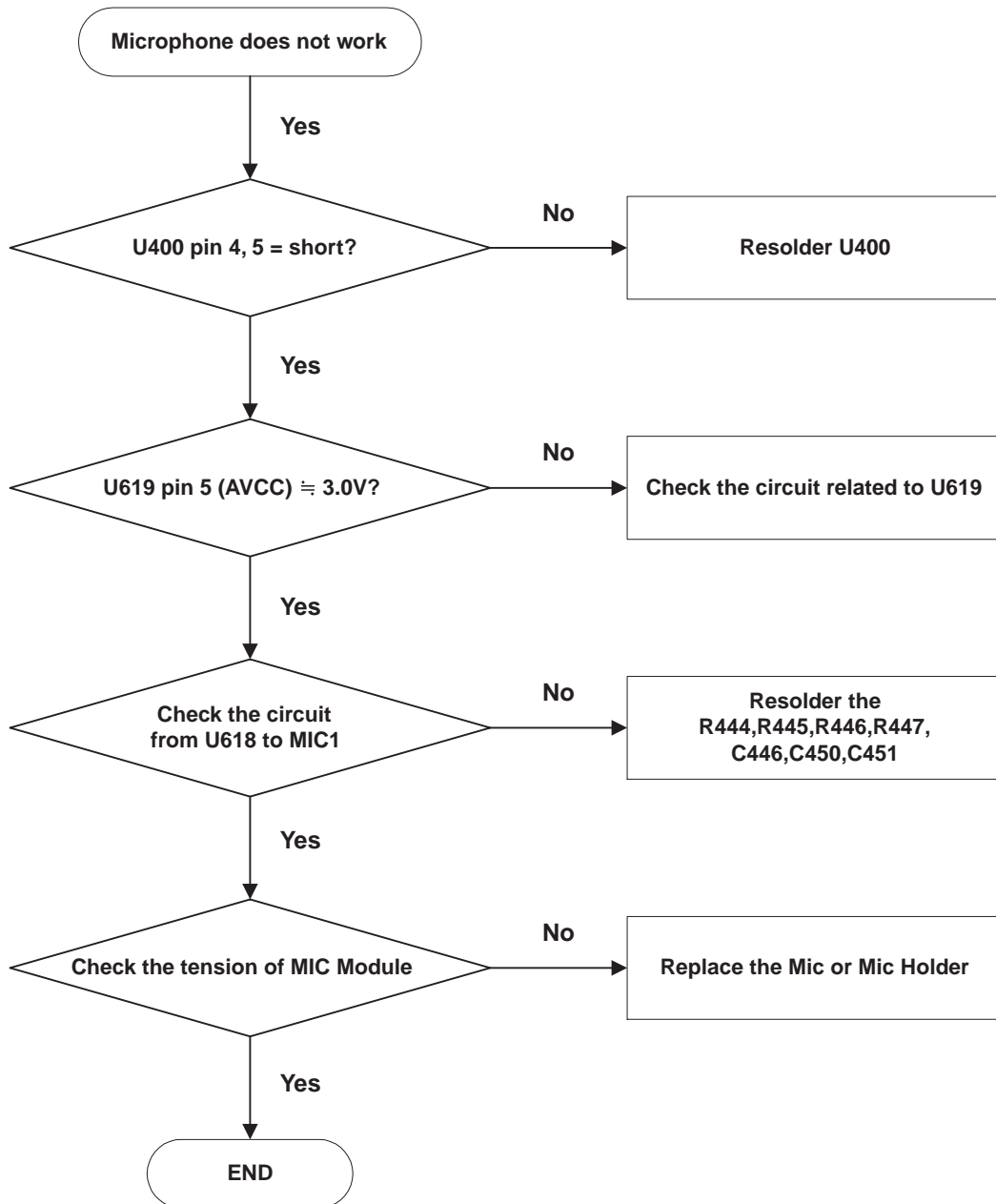

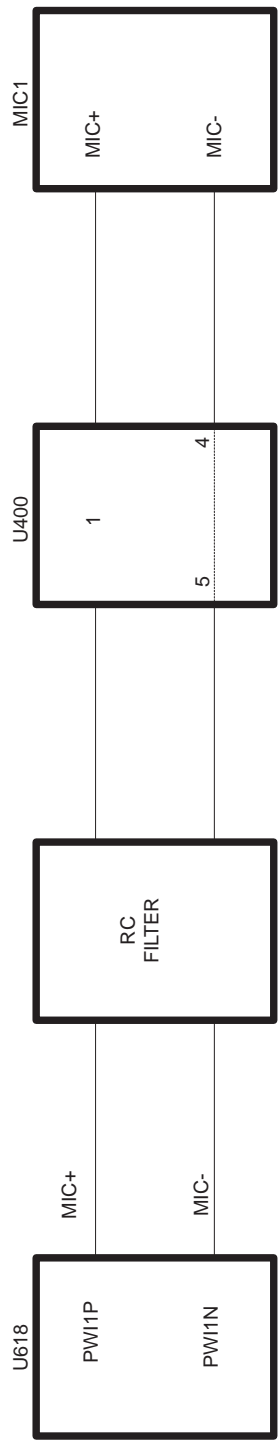

5-6 Speaker Part

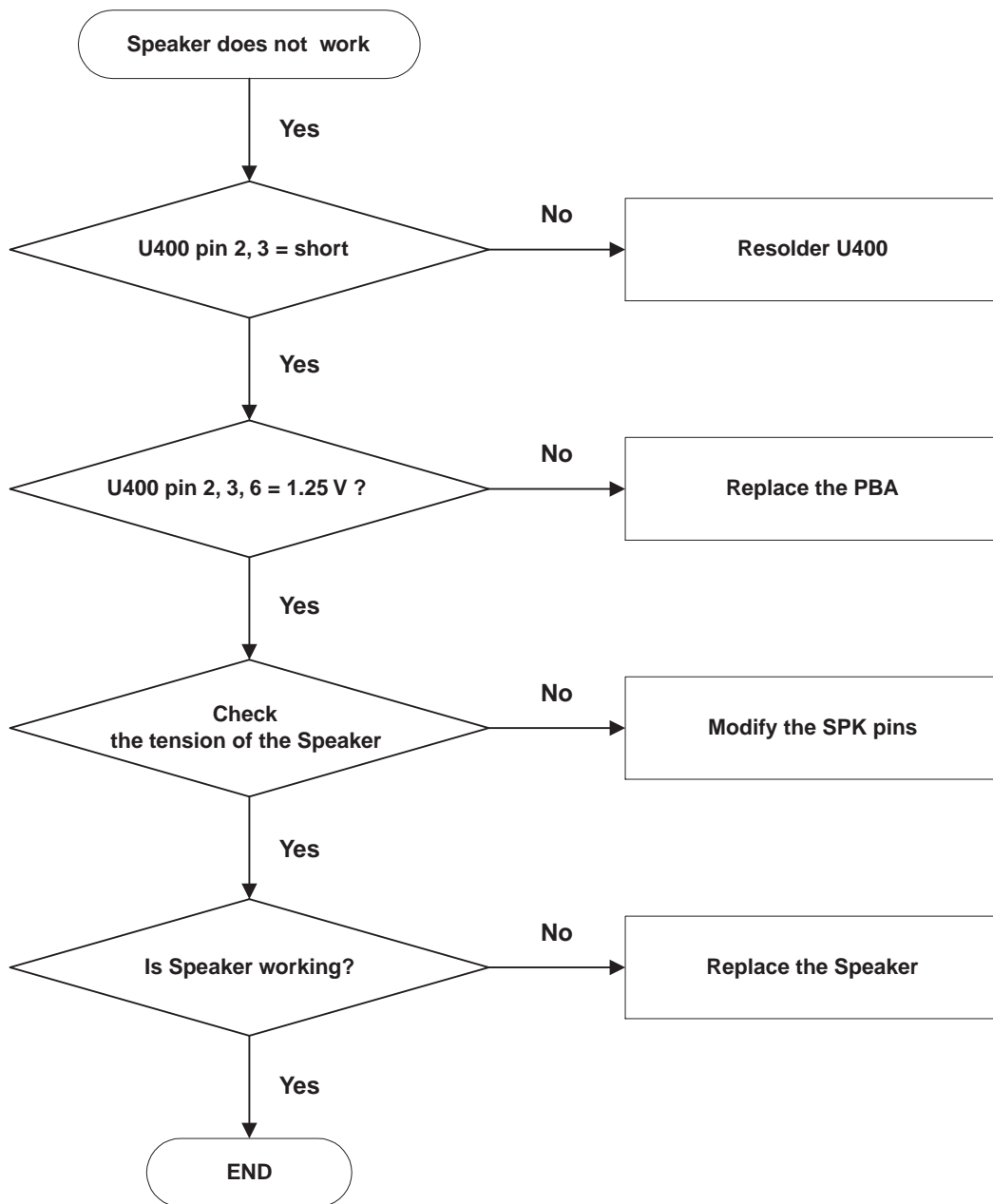

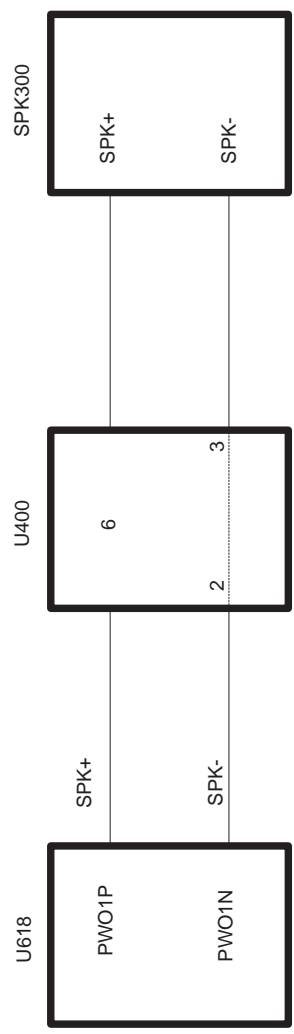

5-7 Key Data Input

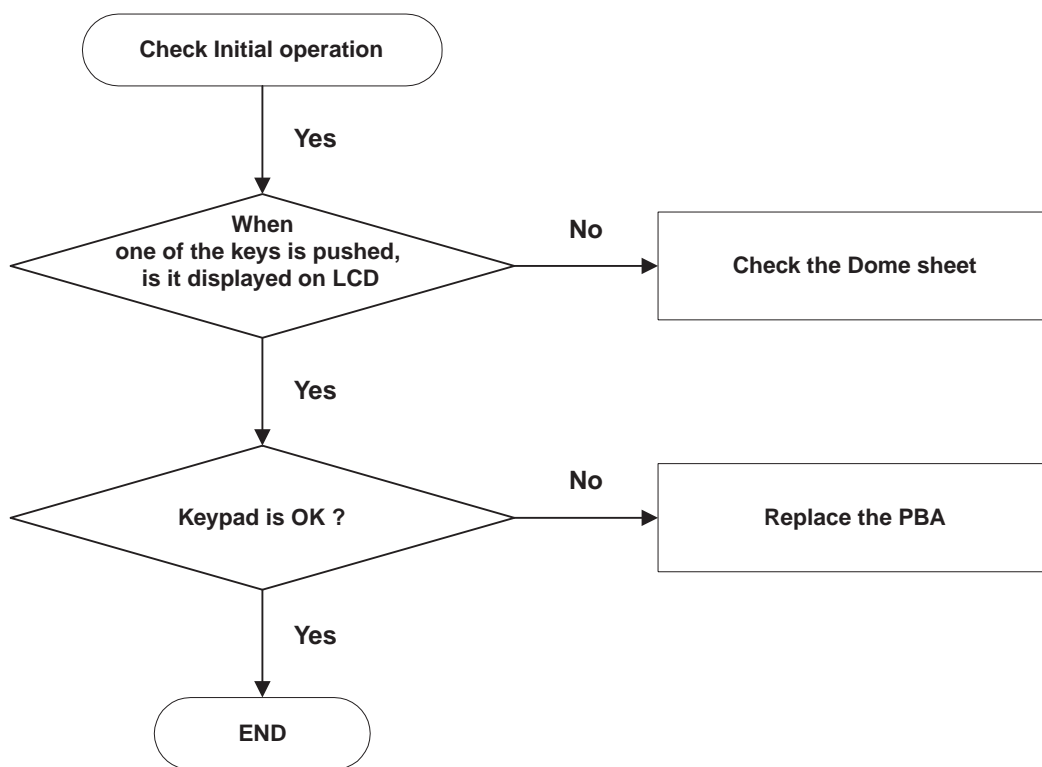

5-8 Alert Tone

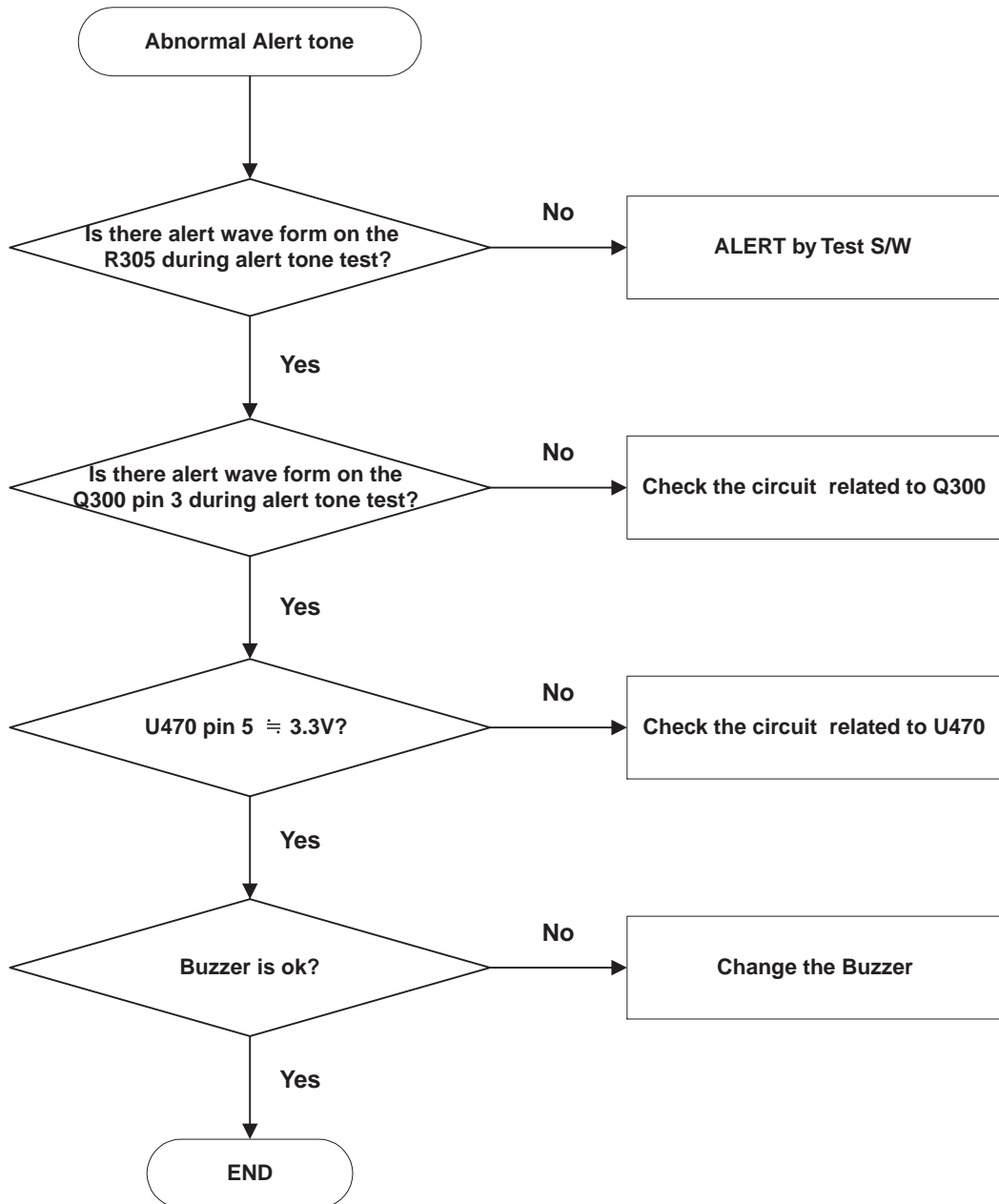

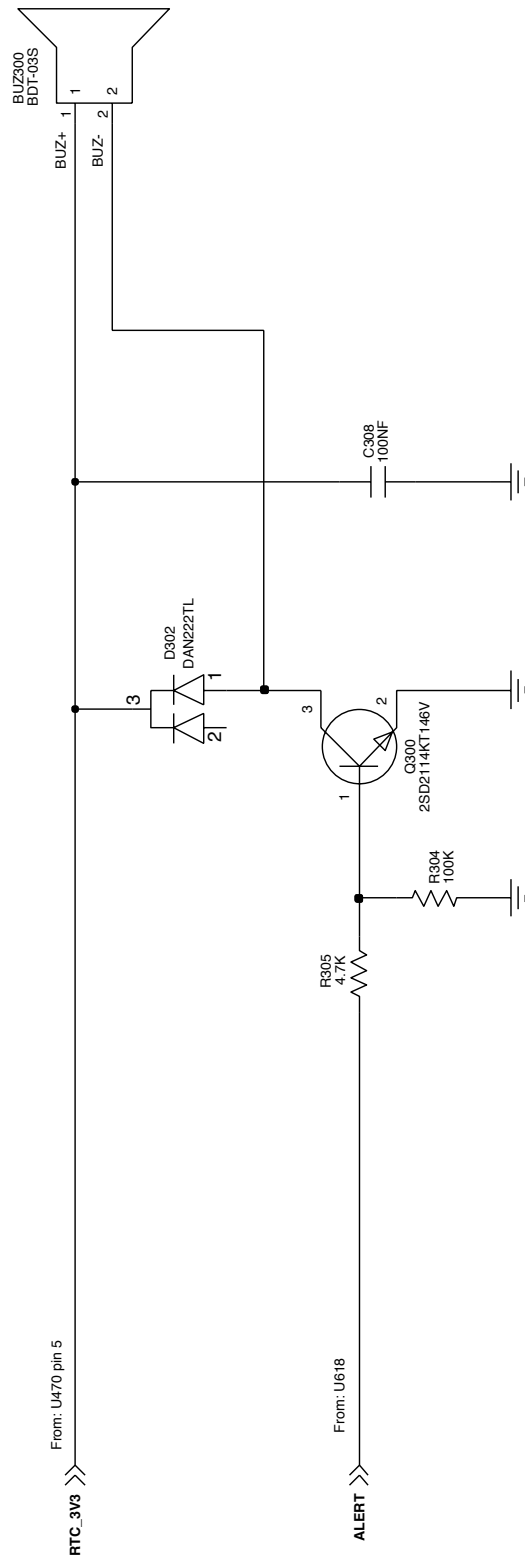

5-9 Ring Indicator

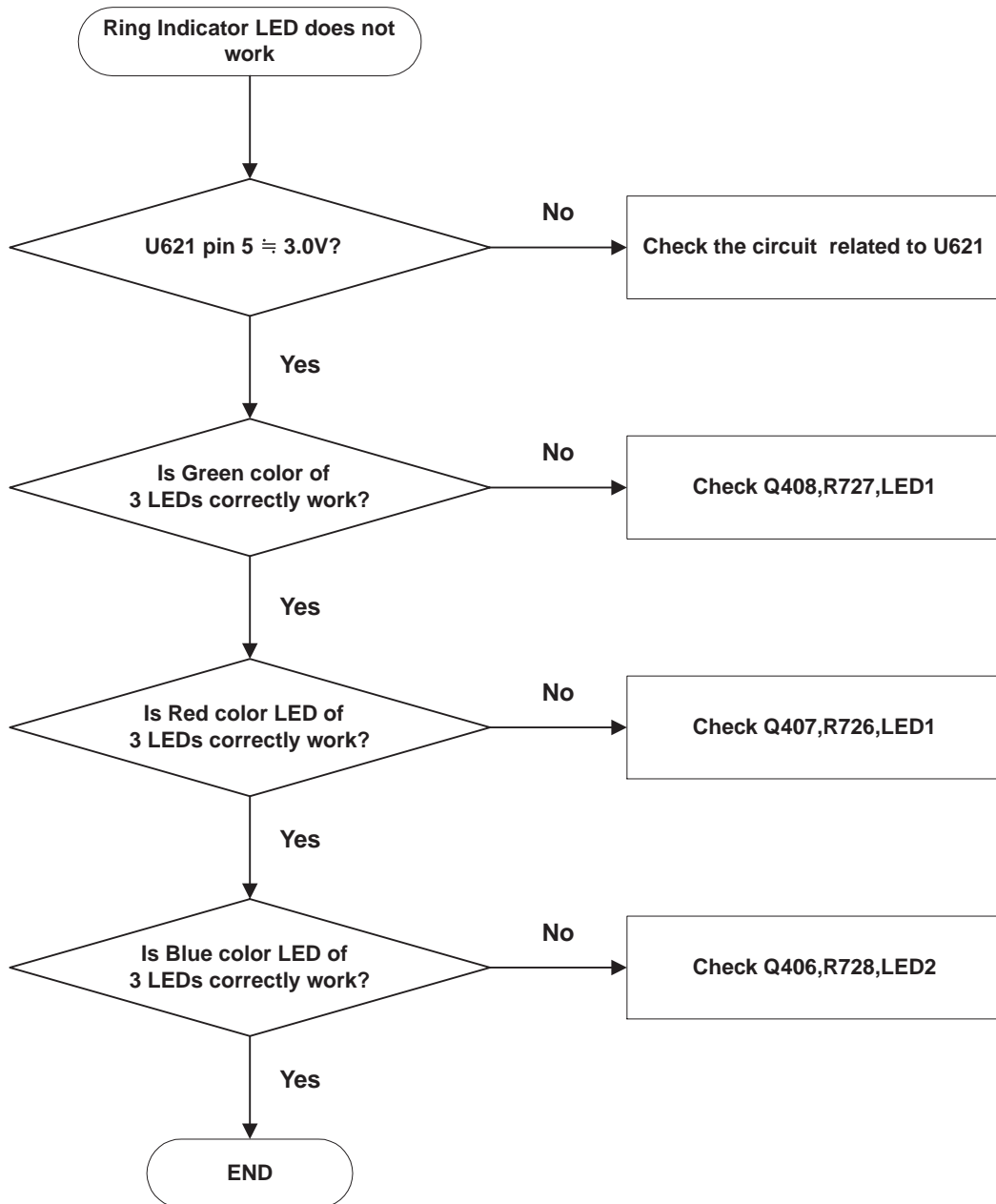

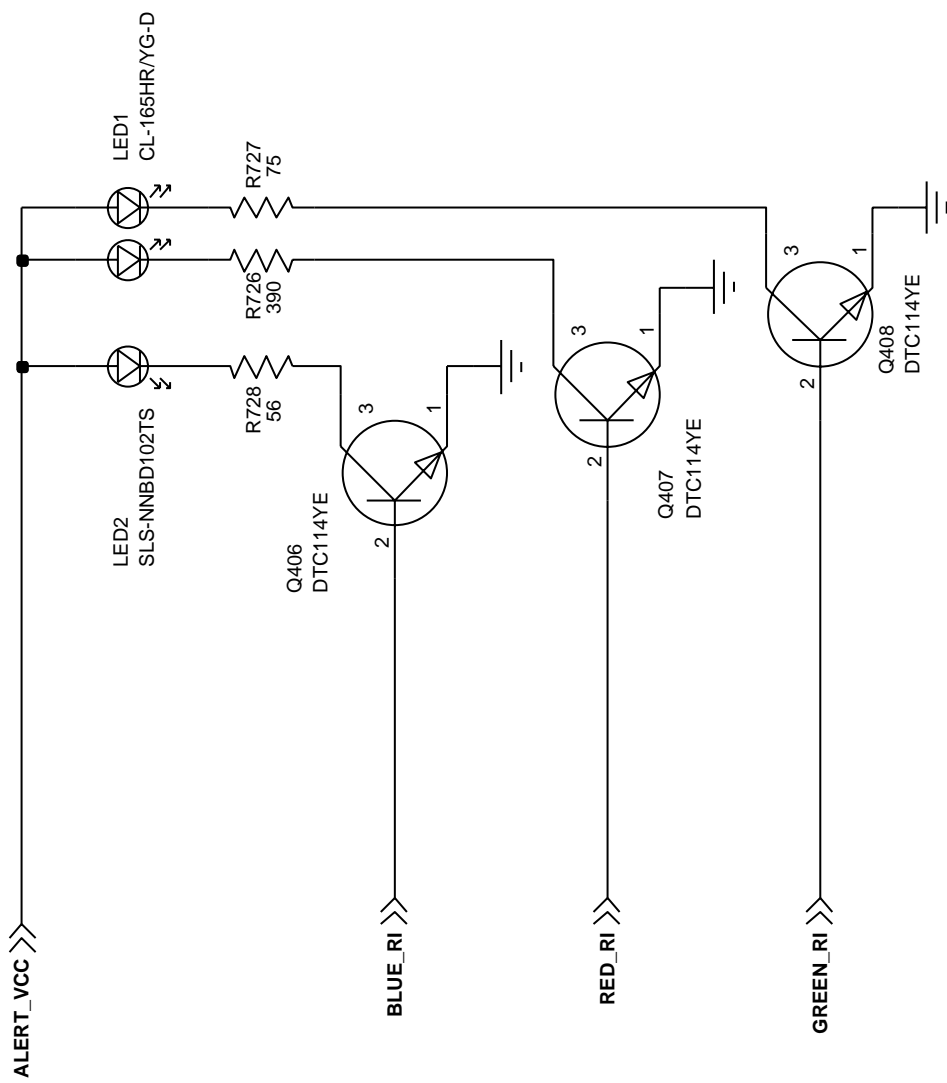

5-10 Back Light

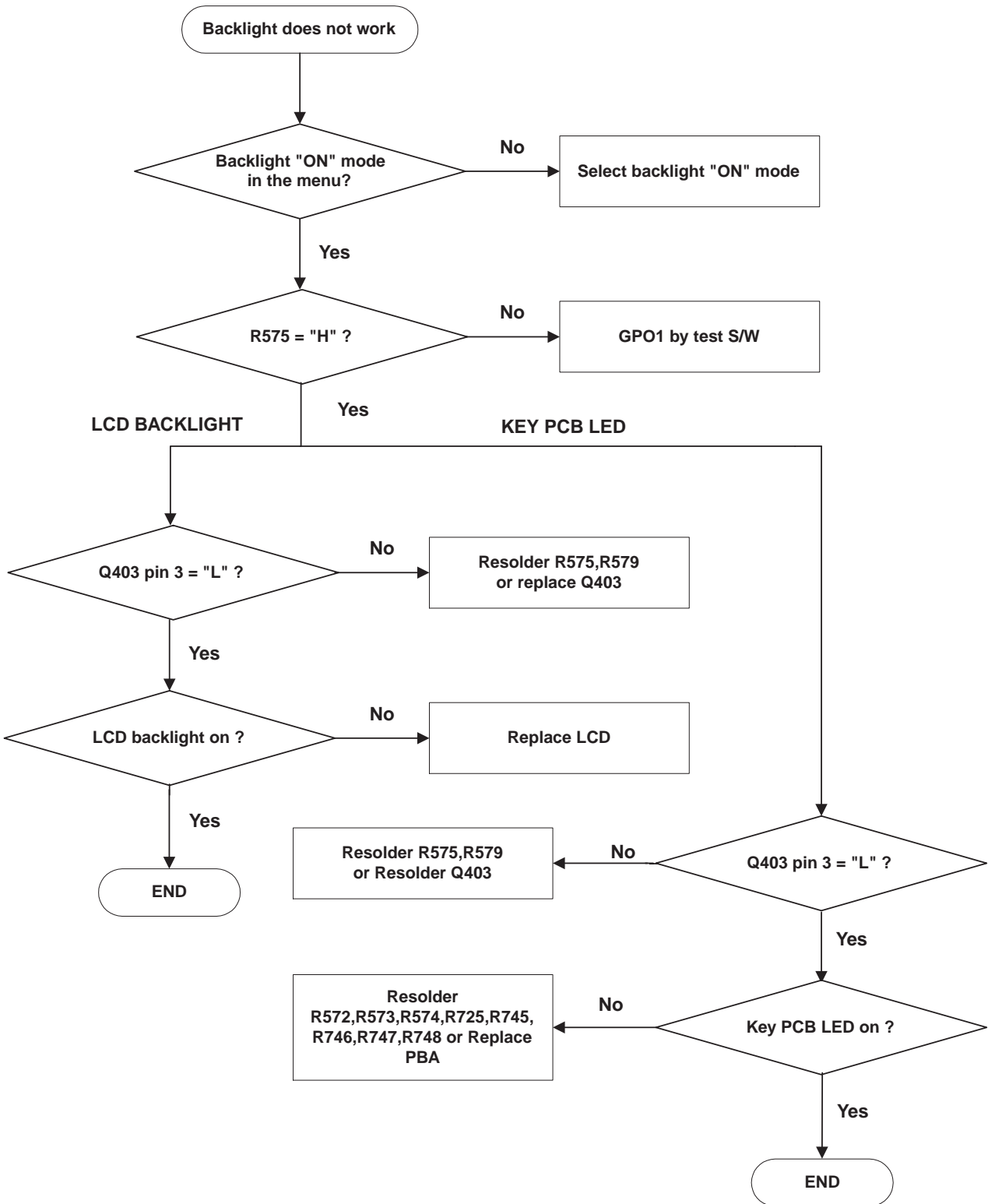

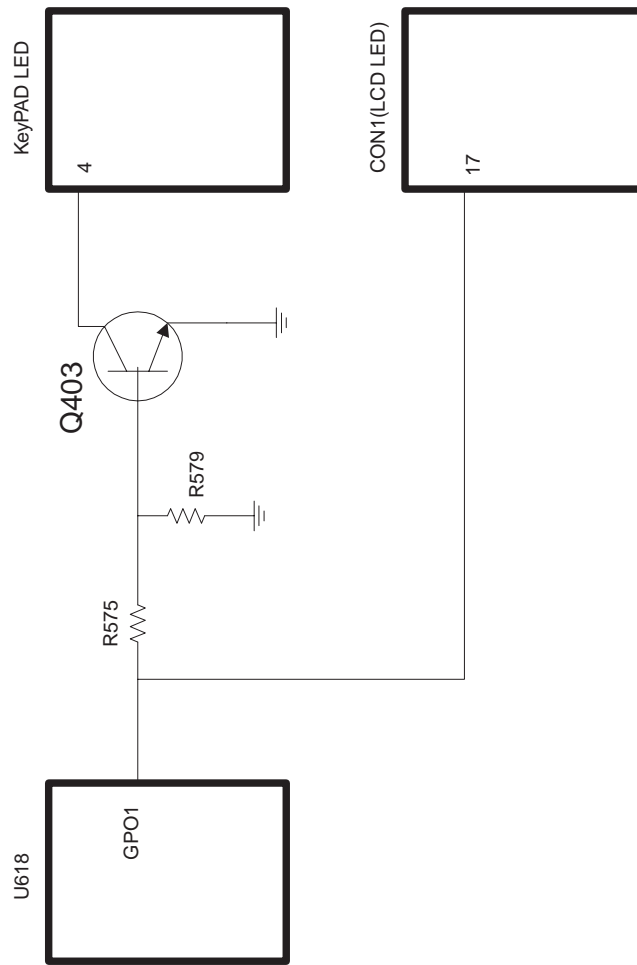

5-11 GSM Receiver

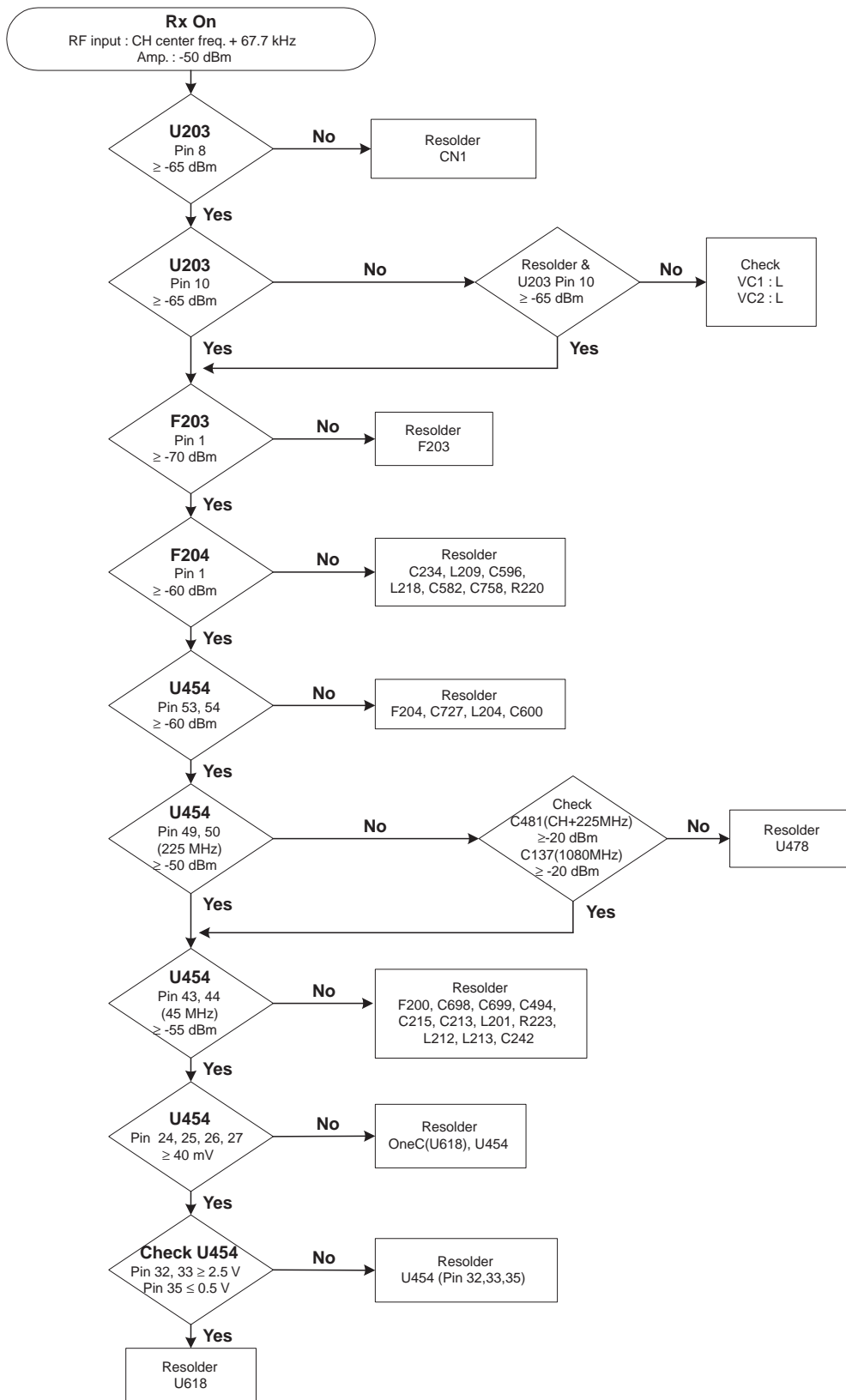

5-12 GSM Transmitter

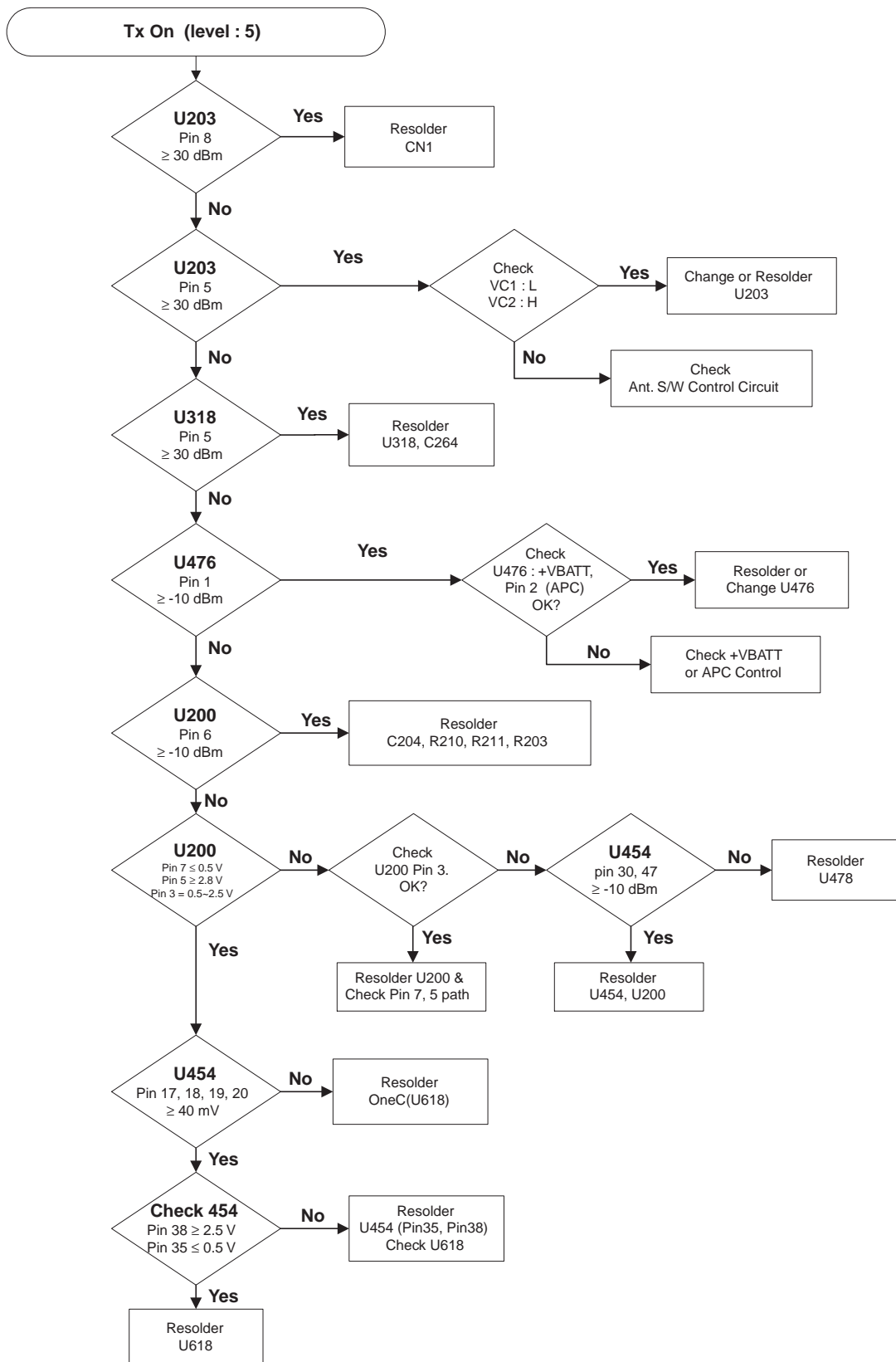

5-13 DCS Receiver

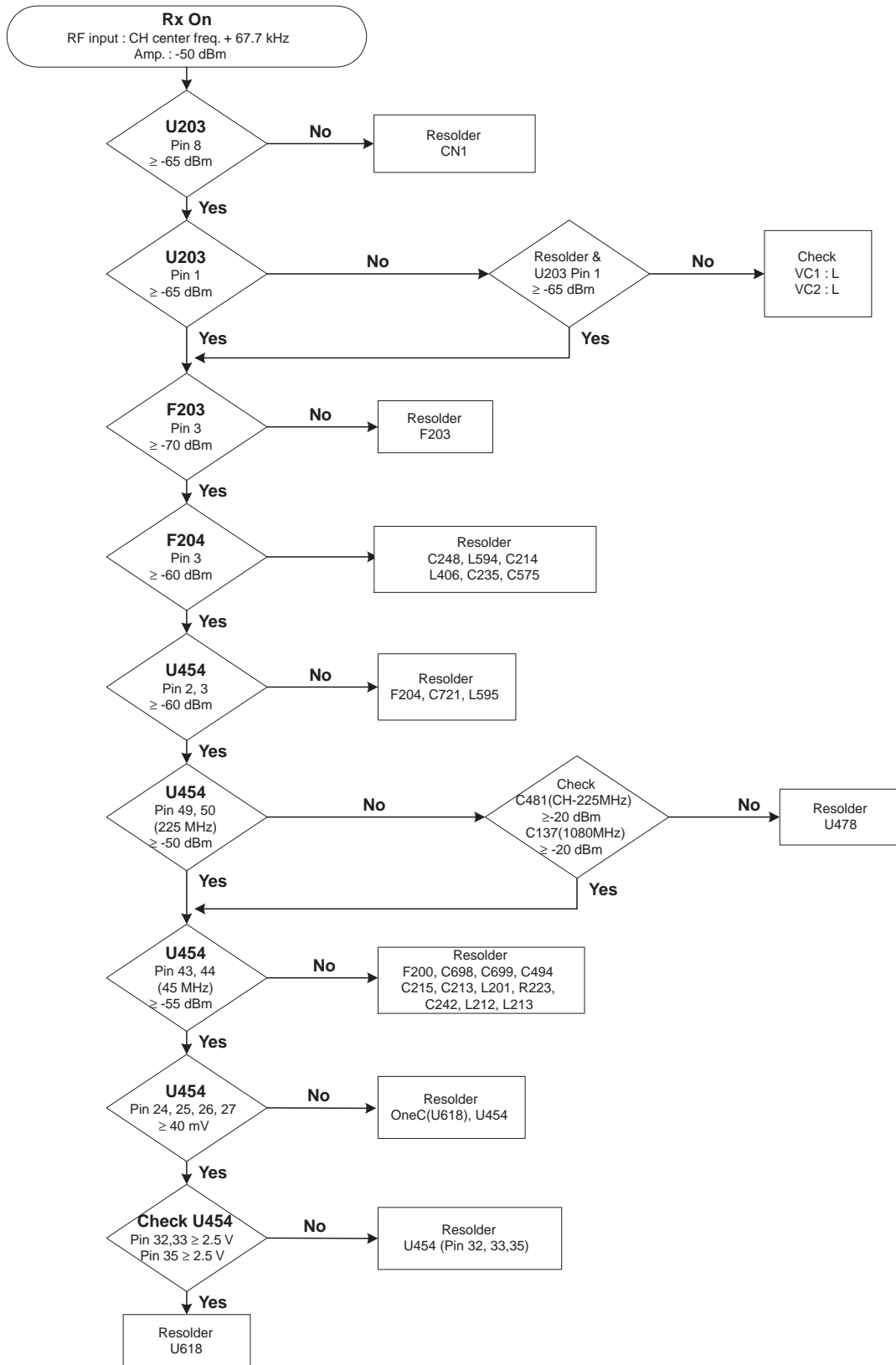

5-14 DCS Transmitter

